

Mars Class 2 Microbiological Safety Cabinets

- Comfort and safe working in today's laboratories.
A choice of a wide range of models and sizes incorporating
Low Energy & Low Noise Technology,
which include the latest International Certification.

*"ScanLaf...Advanced Designs
for your Safety & Comfort"*



Mars

Biological Safety Cabinets
Quality by Definition

...At ScanLaf we know how important it is to select the right cabinets to meet both your technical requirements whilst at the same time providing a comfortable working environment for the operator. The Mars range of Class 2 cabinets provides this and more, especially with their advantage of having today's energy saving and environmental friendly technology built-in.

Mars Class 2 cabinets are better by design for you, your work and for your laboratory.

MARS Class 2 Microbiological Safety Cabinets sets the standards in quality, design, and innovation that comes from a heritage of over 40 years experience.

Inventors of the first electrically operated, angled front screen in the early 1990's, our engineering team are constantly pushing forward the frontiers of energy saving design concepts that others will eventually emulate. Mars Class 2 cabinets are the "science of silence", at < 53 dB(A) you can hear yourself thinking!

Two Mars Class 2 cabinets have been tested and certified by TÜV Nord and conform to EN12469:2000-09 and are so registered and certificated. This certification also confirms that they conform to the requirements of the Equipment & Product Safety Act-GSPG§7(1).

Quality with Quietness is the ScanLaf trademark. Because of the low noise level, check the control panel to ensure the cabinet is running...its that quiet!



Optimal Operator Comfort

- Angled front window gives correct ergonomic working position
- Side windows and glare free rear wall for ultimate visibility & comfort
- Diffused laminator allows shadow-free, variable light distribution in the chamber
- Push button, electrically operated front window with fully open/closed positions
- Easy cleaning and decontamination
- Large work area with air grills on rear wall



The ergonomically correct sloping front and glare-free lighting gives a comfortable, stress-free working position when either seated or standing.



Sectional work top for easy removal and cleaning by one person. Easily autoclaves if so required.



Laminator technology ensures glare-free, diffused lighting and uniform laminar air flow inside the work area.

Maximum Operator Safety

- Downflow & exhaust fans are constantly monitored via the downflow sensors to ensure safe operating conditions are maintained.
- Visual and acoustic alarms for indication of unsafe air-flow conditions or interruptions.
- V shaped, angled front air intake grills, allowing a comfortable work position, whilst obviating restriction of the airflow that maybe caused by incorrect positioning of equipments in the chamber.

Energy Saving Benefits

The Mars Class 2 cabinets have been engineered to take full advantage of the latest energy saving components available today and this is exemplified by the utilisation of **EC* Fans** both for downflow and extract air, equating to an energy consumption of only 0.9 amps.

The innovation of using 3 or 4 low energy fans in the Mars cabinets, as compared to 2 AC fans, as in most other safety cabinets, also allows for a less restricted construction whilst at the same time giving the advantage of incorporating 11 cm deep HEPA filters, which give a longer working life.

Low energy consumption also results in less heat transmission to the work chamber thereby lower evaporation rates to any samples in the clean area and consequently lower air conditioning demands for the whole laboratory. This all adds up to significant reductions in overall running costs.

EC Fans by EBM-Papst™ are DC output fans with integrated AC converters and are at the leading edge of energy saving technology in motor design and offer the following advantages:

- Digital control & operation
- Greater efficiency with less energy consumption than conventional AC fans
- Lower operating temperatures & increased operational life
- Quieter in operation, < 53 dB(A) in the Mars Class 2
- Control & monitoring of operating speeds with Alarm outputs
- Reduced starting current

Precise digital control of the Mars cabinet via regulation of the EC fans allows for direct setting of the fan speeds required, giving up to 85 % more power as compared to conventional analogue regulation with AC fans. This all equates to much lower noise levels and correspondingly reduced energy consumption, resulting in lower operational costs.



Comfortable working position without restriction of the Angled front air inflow grills.

Microprocessor Control

- Precise, direct fan speed settings, control & measurement giving low noise levels
- Airflow control for down flow & exhaust air measurement with precise alarm settings
- Pressostat option
- Energy saving reduced speed facility for fast, safe start up and for maintaining cabinet integrity whilst cabinet is unattended
- Decontamination program for either Formalin or VHP
- Automatic start up/shut down via time setting

Precise digital control of the cabinet via regulation of the EC fans allows for direct setting of the fan speeds required with up to 85 % more power compared to conventional analogue regulation. This equates to much lower noise levels and correspondingly much lower energy consumption, therefore lower running costs.

Additionally a Pressostat can be incorporated if required, to measure the pressure across the main HEPA filter, giving an indication of any restrictions or blockage.

Eye Level Microprocessor Control

- Gives view of all cabinet functions from both standing or seated position
- Functions for full or reduced fan speeds, resettable hour counter, lighting level
- UV light timer, exhaust & downflow alarms, window position alarm
- Service program access via key pad code

The Microprocessor Control panel with LCD display controls all functions of the cabinet and is conveniently placed for easy viewing and operation from either a seated or standing position.

Incorporating a “real time” clock for programming auto start up/auto close down, it also includes functions for reduced speed, resettable hour counter, lighting with variable adjustment 0-2000 lux and UV timer. All alarms for exhaust and downflow air and window position are indicated visually and audibly. A Decontamination programme for either Formalin or VHP can also be included. Service access is also provided, protected via a key pad code and all settings and adjustments can be checked or changed through the controller. The digital fan system and alarm thresholds are precisely controlled via the microprocessor which guarantees excellent airflow performance.

UV Light

A UV light for decontamination of the work surfaces or for deactivating DNA can be supplied in the interior of the work chamber and located out of direct view. This can also be purchased and fitted retrospectively and the microprocessor programmed accordingly. The operation of the UV light, via the control panel, can be adjusted for timed delay start and stop of the exposure time or can be programmed to be operational whilst the laboratory is unattended, i.e. at lunch break or during the night time. An alarm indication for UV tube replacement is also included. This offers the highest safety protection and convenience for the operator.

USB Port

A USB port option is available and facilitates the monitoring and documenting the full performance of the Mars cabinet via a PC for GMP work. This allows daily logging of the air flow speeds, alarm activation and all settings and functions used, when and where. This is also open communication channel platform for external control units, i.e BMS systems, Central building alarm systems etc.



Eye level control panel can be viewed and operated from either a seated or standing position by the operator.

Compact Design

The low cabinet height 1.248 metres allows the choice of bench top location or mounting on a support stand- with working height at 75 cm the total height is < 2 meters - a recirculating cabinet should have a minimum 20 cm clearance above the cabinet to allow for unrestricted exhaust airflow.

The overall dimensions of the Mars allows for easy positioning and relocation without the need for disassembly, can be easily transported through standard 800 mm doorways.

There are 4 sizes of adjustable support stands for the Mars cabinet, including an Electric Elevation stand which can vary the working height between 75 cm to 105 cm. Easily adjusted by push-button operation to the height position convenient for the operator, whether seated or standing. At the fully adjusted height of 105 cms the overall height of the cabinet + stand is only 2.353 metres, easily accommodated in a laboratory with 2.5 m ceiling height.

AirFlow Pattern

The Mars's unique design incorporating laminator technology with 2 downflow fans and a single exhaust fan, digitally controlled, ensures true laminar and turbulent-free air flow distribution throughout the work chamber. This advancement results in lower noise levels, a vibration free work area coupled with a longer filter life-time.

This makes the Mars Class 2 cabinet the Lowest and most versatile cabinet in the World!



Slim, compact design and dimensions allows for easy positioning and location in the laboratory.

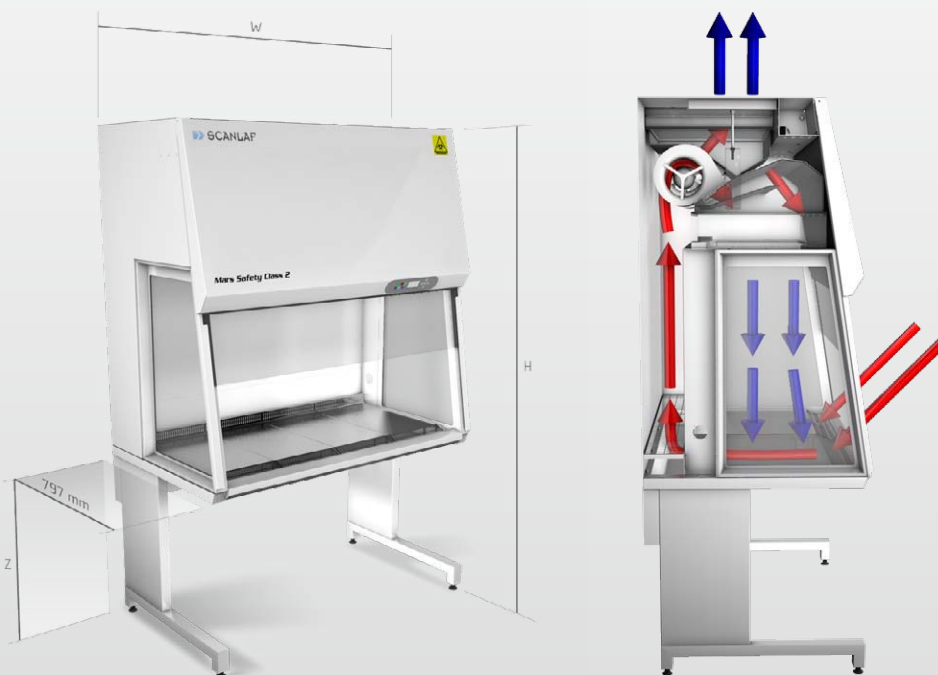

Mars model	Width (mm)
Mars 900	1003
Mars 1200	1305
Mars 1500	1610
Mars 1800	1915

With Electrical elevation stand

Z Support Stand Height	Height (mm)
725 ± 25	1999 ± 25
825 ± 25	2099 ± 25
925 ± 25	2199 ± 25

Stroke	Z Stand	Height (mm)
Min	717	1993
Max	1017	2293

Connection to External Ducting

The extraction of exhaust air from the Mars Class 2 cabinet is usually achieved by either a dedicated or "shared" extract duct, in either case it is always via an anti-blow back valve mounted on a plenum which covers the exhaust filter aperture.

These two extract connections are referred to as a Hard Duct or a Thimble Duct respectively, the latter is extracting air from the laboratory also. (See diagrams)

The Mars Class 2 cabinet, ducted either way, can have a working height of up to 90 cms in a laboratory with a ceiling height of 2.4 metres or 100 cms working height in a laboratory with a 2.5 metres ceiling height

...This makes the Mars Class 2 cabinet the Lowest and most versatile cabinet in the World!

- Provision of 3rd Pressure sensor in duct for airflow monitoring
- Provision of potential free contact for connection to Central Alarm or BMS system
- Connection for ducting Damper valve

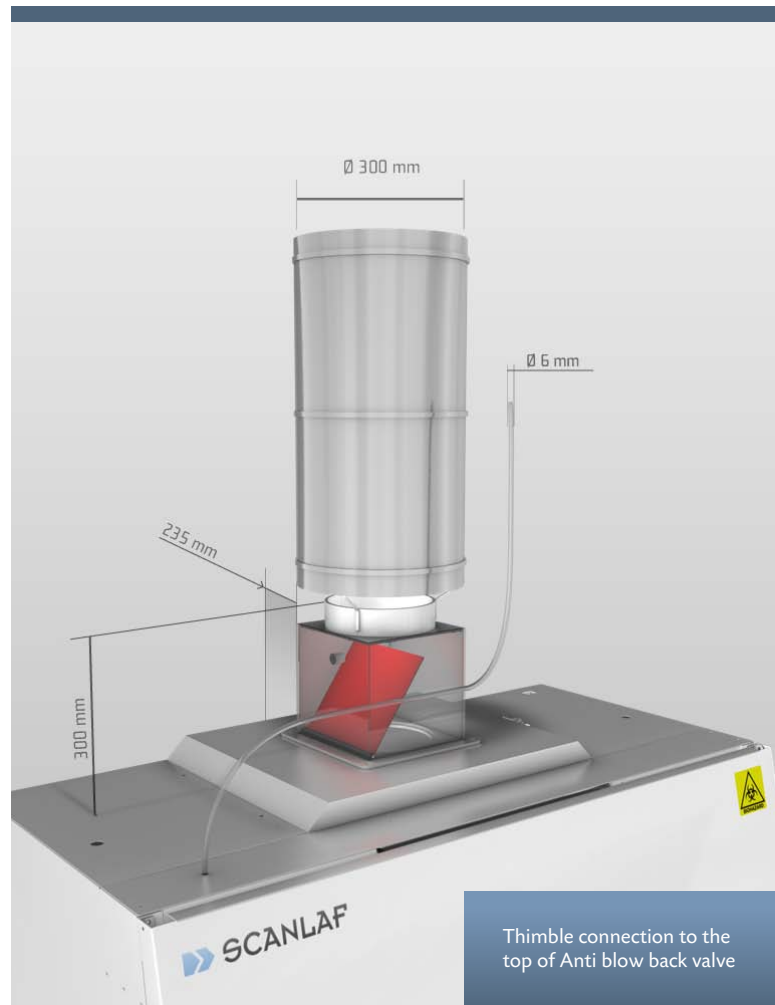
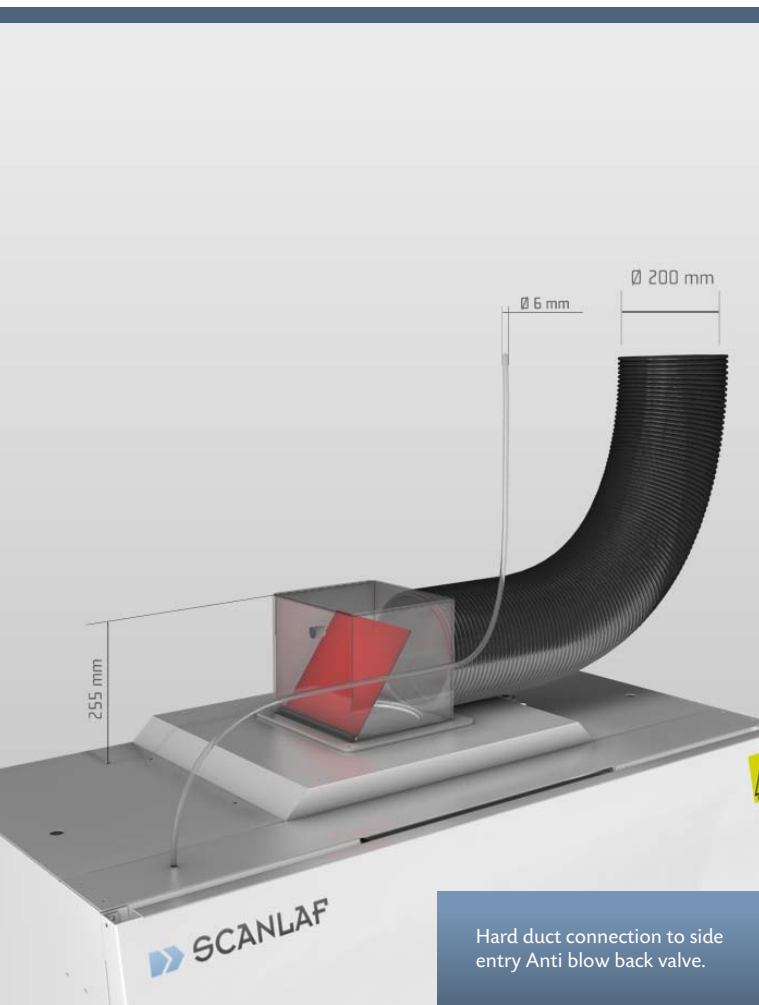
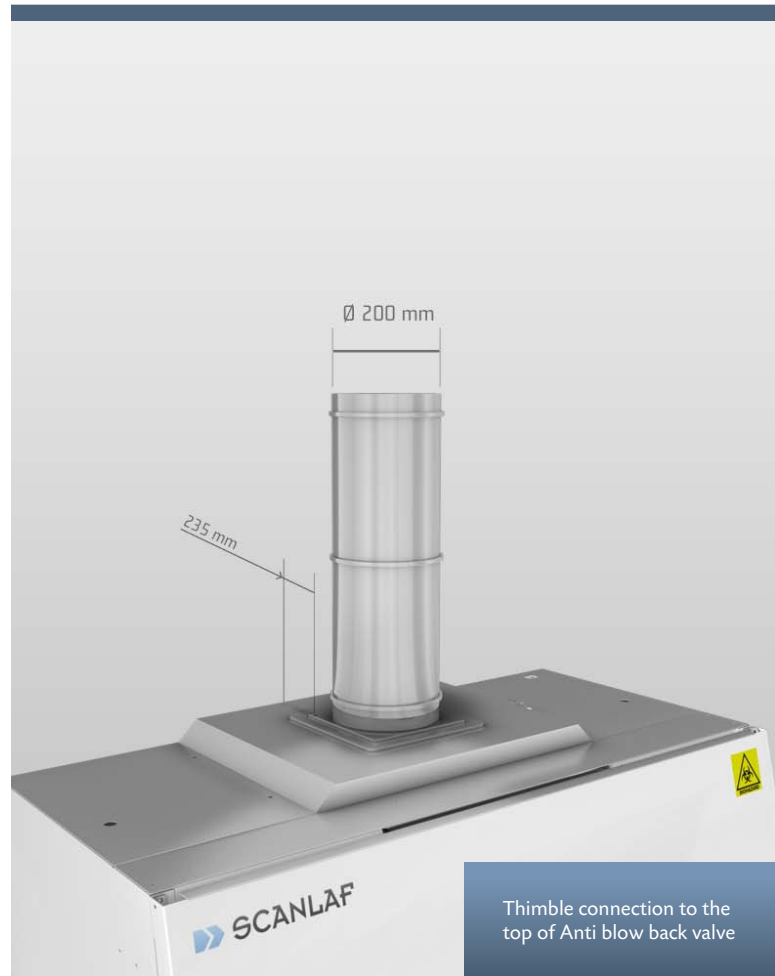

Auto Start-Auto Stop option with Eco-Save™

The Mars Class 2 Microbiological Safety Cabinet is the world's first to incorporate **Eco-Save™**, a PIR (Passive Infra Red) motion sensor system, that gives:

- Hands free start-up & switch off
- Ensures product protection whilst unattended
- Maintains the cabinets integrity, in reduced fan speed mode, whilst not in use
- Saves up to 80% energy in operating costs

How does it work?

When the operator places their hands through the work opening the cabinet is activated from reduced fan speed to operational full fan speed and the interior lighting switches on.

On completion of the work and when the operator removes their hands from the work area, after a delay of approximately 10 mins, the fans automatically revert to reduced speed mode and the interior lighting switches off.

By using this option in conjunction with the microprocessor controller to program the timing of the cabinet's start-up and switch off during the working day, up to 80 % of operating energy costs can be saved. No buttons or knobs to press, complete safety and economy with the **Eco-Save™** system.

This gives highest operator comfort at the same time highest safety as the cabinet is always safe and ready to use.

Options & Versions

The design & construction of the Mars Class 2 cabinet allows for many options to the standard cabinet or specific versions for applications where Class 2 protection is required or advisable.

Options

- USB port for pc connection, data logging or air flow speeds, alarms, settings. Link up to BMS or central alarm systems 3rd Sensor connection for exhaust air measurement in connected ducting
- High Work opening of 30 cm (standard 20 cm) to front window
- Electrically operated, elevated support stand
- Eco-Save auto start/auto stop using PIR sensor (Passive Infra Red) see details below

Versions

- Mars-IVF with integration of microscope and heated/cool platens in work surface
- Mars-Weigh Master with/without marble insert balance platform, computer screen integrated in rear wall
- Mars-Iso with lead protection on under bench trough, lead glass to all windows, including front screen
- Mars-B2 class 2 with 100% exhaust and safe change filter system

If you have a specific requirement for a "specific class 2 cabinet", let us know the application and our specialist engineers will be able to advise and invariably offer a solution.

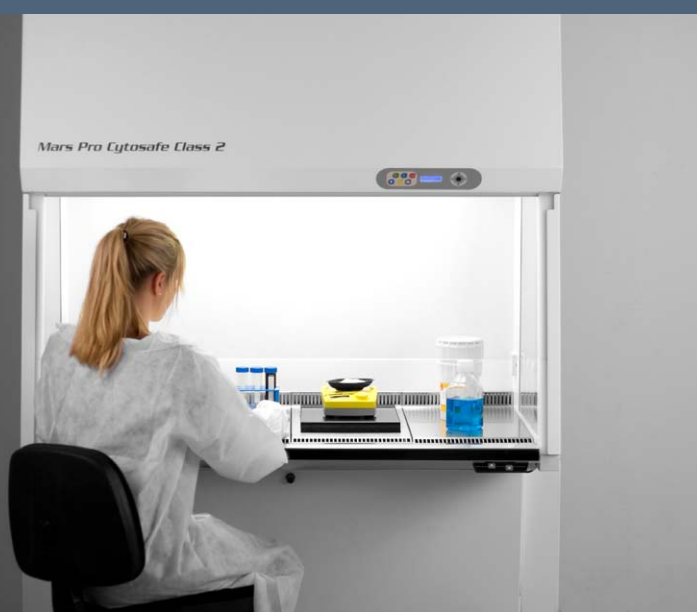

Options

The design & construction of the Mars Class 2 cabinet allows for many options to the standard cabinet or specific versions for applications where Class 2 protection is required or advisable.

- Support stands of clean room design and high stability allows easy lifting by pallet truck or fork lift. Available with castors (option) for easy re-location or transportation. Standard heights available in 75 cms, 80 cms, 90 cms + 5 cms and also electric elevation with variable height adjustment
- Marble insert to work top section for weighing applications to 5 decimal places
- Valves for Gas; Vacuum; Nitrogen; Compressed Air, mounted on side window
- Built-In computer screen on rear wall or attached with magnetic mountings
- Safety operated Bunsen Burner
- Heated work top panel 300x450 cm with thermostatic circulator control and placement shelf
- Sink fitted into work top 325x325x200 cm, AISi 304 stainless steel with water tap, located on LHS or RHS - please specify

The standard work tops of the Mars Class 2 cabinets are constructed in 30 cm sections for easy removal and cleaning on all surfaces which can easily be autoclaved if required. Consequently the Mars 1.2 has 4 sections. Other options are available to suit customer requirements, either a single one piece work top or a three part work top consisting of 2 end sections of 30 cms and a central section of 60 cms. This flexibility of work top choice enables the Mars to be configured to suit your exact practical requirements.



Mars 1.2 with alternative section work top.

Service valves for Air, Nitrogen and Vacuum mounted on side window.

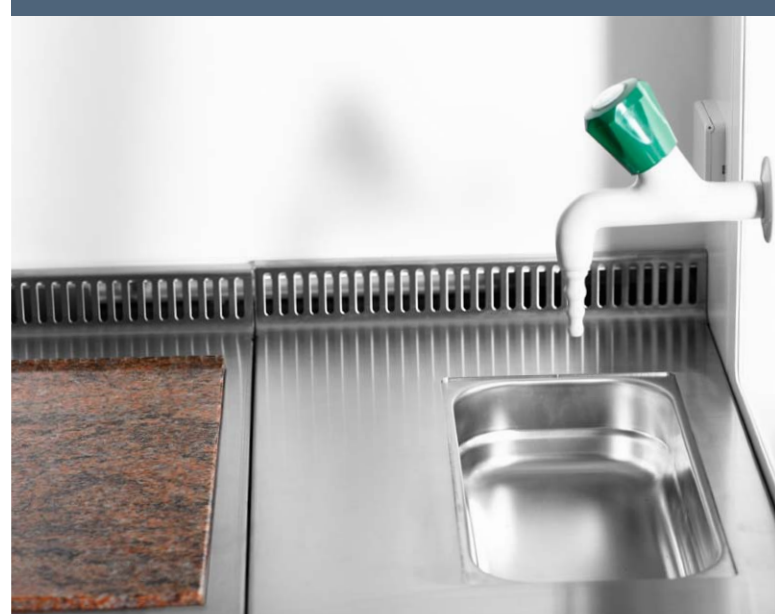
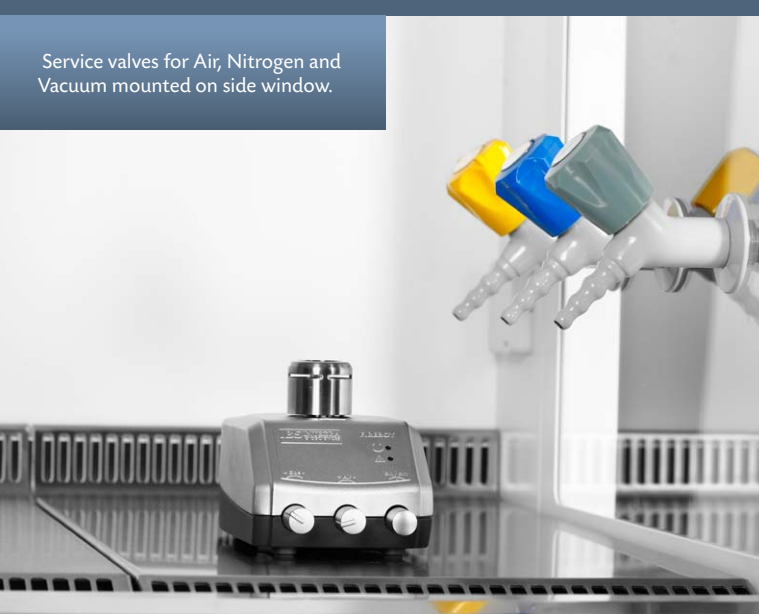

Service Access

All Service and adjustment procedures are performed from the front of the cabinet, including exchange of HEPA filters, changing or adjustments to circuit boards and sensors.

All alarm functions, fan speed and DOP valve changes and are made via the Microprocessor Control panel, the Service Mode function of which is password protected.

Consequently, the cabinet can remain in situ without making any positional changes in your laboratory or having to disconnect any ducting.

All service is performed from the front of the cabinet, including:

- Change of HEPA filters
- Adjustment or change of circuit boards and sensors
- All adjustments to alarms, fan speeds, and DOP valves are made via the microprocessor control panel
- Service code protected



Model	Unit	M900	M1200	M1500	M1800
Catalogue no.		9.001.023.000	9.001.020.000	9.001.022.000	9.001.021.000
External dimensions (DxWxH)	mm	798x1003x1248	798x1303x1248	798x1603x1248	798x1903x1248
Working chamber, dimensions (DxWxH)	mm	650x900x720	650x1200x720	650x1500x720	650x1800x720
Working height	m	Work height off 0.75-1.10 in 2.50 rooms			
Front opening	mm	200 optional 300			
Air velocity, vertical flow	m/s	0,28 (adjustable 0,25-0,55)			
Air velocity, deviation	±%	10	10	10	10
Down flow rate	m ³ /h	500	650	810	975
Exhaust flow rate	m ³ /h	260	350	440	520
Noise level, ISO 6081	dB(A)	<53	<53	<54	<54
Light intensity variable	Lux	0-2000	0-2000	0-2000	0-2000
HEPA filters, EN 1822		Efficiency is 99.999 % against 0.3 µm particle H-14 size 99.995 % in MPPS			
V-shaped table tops		Yes	Yes	Yes	Yes
Clean room box design		Yes	Yes	Yes	Yes
Excellent light distribution		Yes	Yes	Yes	Yes
Electrical sliding windows		Yes	Yes	Yes	Yes
Window cleanable on both sides		Yes (side windows only if space around allows cleaning)			
Voltage/frequency	V/Hz	220-240/50-60 or 110-120/50-60			
Power consumption	W	150	175	200	225
Fuses	A	10	10	10	10
Net weight	kg	225	250	275	300
Shipping volume	m ³	2.2	2.9	3.2	4.1
Window material		Hardened/laminated safety glass			
Cabinet material		Polyester coated steel/AISI 304 Stainless steel			



Mars Pro Cytosafe Class 2 – 3 filter cabinet.

Orion Ultrasafe B2 Class 2 cabinet.



LaboGene™ is a Danish Company that specialises in the design, development, manufacture and sales of laboratory and industrial equipments in the fields of Clean Air & Laminar Flow, Vacuum & Cooling and Centrifugation.

Clean Air & Laminar Flow

ScanLaf represents the best in Class II and laminar flow cabinets with the advantage of low energy consumption, digital control and ergonomic design. The Industrial **ScanLaf** program offers a range of Down Flow modules and enclosures for powder and animal handling as well Air showers and Glove boxes, all of which can be produced to Customers specifications. A truly unique bespoke portfolio!

Vacuum & Cooling

ScanVac epitomizes the best in Freeze Drying and Vacuum Concentration equipments and offers a wide range of bench or floor standing units with temperatures down to -110 °C.

Together with accessories and components compatible with previous Danish produced models, **ScanVac** can offer continuity of supply, service, advice and assistance.

ScanCool the brand that describes a range of Ultra Freezers for sample storage offering a choice of Chest or Upright models from 100 to 600 litres capacity. Environmentally friendly and energy saving design concepts are standard features of all units in the ScanCool range.

The **ChillSafe** range of cooling & cryogenic baths and circulators with capacities of 8 to 18 litres and temperatures from -30 °C to -90 °C completes the ScanCool offering.

Centrifugation

ScanSpeed, the name that defines quality centrifuges from **LaboGene**. Offering bench-top high and low speed models with or without refrigeration for today's discerning laboratory technician.

Quality engineering with modern designs and features that exemplifies Danish craftsmanship.



LaboGene ApS
Nøglegårdsvej 20
DK-3540 Lyngø
Tel (+45) 3940 2566
Fax (+45) 4498 1741
Mail info@labogene.com
Web www.labogene.com