



**VT-21-250 PSI**  
**VERTICAL STORAGE TANKS**

**1500 Gallons**

**Through**

**15,000 Gallons**

---

Do not attempt to use or maintain these units until you read and understand these instructions. Refer to the Taylor-Wharton's Safety First booklet (TW-202) for handling cryogenic material. Do not permit untrained persons to use or maintain this equipment. If you do not understand these instructions, contact your supplier for additional information.

---

9918-7834  
9/3/02

## TABLE OF CONTENTS

SAFETY PRECAUTIONS FOR LIQUID OXYGEN .....	4
SAFETY PRECAUTIONS FOR LIQUID NITROGEN .....	6
INTRODUCTION.....	7
FUNCTIONAL DESCRIPTION.....	7
Tank Construction .....	7
Piping .....	7
Fill.....	8
Withdrawal and Economizer .....	8
Pressure Building .....	8
Safety Devices.....	9
Instrumentation .....	9
Vacuum System .....	10
INSTALLATION.....	11
Handling.....	11
Installation Checks.....	12
Customer Installed Equipment.....	12
Rigging.....	14
OPERATION .....	17
Purge Procedure.....	17
Filling a Warm Tank.....	18
Filling a Cold Tank.....	19
Normal Operation .....	20
Taking a Tank out of Service .....	21

Tanks in Oxygen Service.....	21
Tanks In Nitrogen/Argon Service.....	21
MAINTENANCE.....	22
General.....	22
Leak Testing.....	22
Hand Valves.....	22
Control Valves.....	23
Resetting Control Valves.....	23
Setting PRESSURE BUILDING REGULATOR (PCV-1):.....	24
Setting ECONOMIZER BACK PRESSURE REGULATOR (PCV-2):.....	24
Inner Vessel and Piping Safety Devices.....	25
Pressure and LIQUID LEVEL GAUGES.....	25
CASING VACUUM MAINTENANCE.....	26
Checking Vacuum.....	26
Vacuum PROBE (VR-1) Replacement.....	27
Analyzing Vacuum Deterioration.....	27
PAINTING.....	28
Safety Precautions Pertaining To Painting Operations.....	28
TROUBLE-REMEDY GUIDE.....	29
RECOMMENDED TOOLS, EQUIPMENT, AND MATERIALS.....	31
REPLACEMENT PARTS.....	31

**WARNING**

**Following safety precautions are for your protection. Before performing installation, operating, or maintenance procedures read and follow all safety precautions in this section and in reference publications. Failure to observe all safety precautions can result in property damage, personal injury, or possible death. It is the responsibility of the purchaser of this equipment to adequately warn the user of the precautions and safe practices for the use of this equipment and the cryogenic fluid stored in it.**

## **SAFETY PRECAUTIONS FOR LIQUID OXYGEN**

Oxygen is a colorless, odorless, and tasteless gas that can be condensed into a liquid at the low temperature of 297 degrees below zero Fahrenheit (-183°C) under normal atmospheric pressure. Approximately one-fifth of normal air is oxygen. As a liquid, oxygen is pale blue in color. Oxygen is non-flammable but vigorously accelerates the burning of combustible materials.

### **Keep Combustibles Away from Oxygen and Eliminate Ignition Sources**

Many substances, which do not normally burn in air, require only a slight spark or moderate heat to set them aflame in the presence of concentrated oxygen. Other substances, which are only moderately combustible in air, can burn violently when a high percentage of oxygen is present.

Do not permit smoking or open flame in any area where liquid oxygen is stored, handled, or used. Keep all organic materials and other flammable substances away from possible contact with liquid oxygen. Some of the materials that can react violently with oxygen are oil, grease, kerosene, cloth, wood, paint, tar, and dirt, which contains oil or grease. Under certain conditions flammable materials, which have become permeated with liquid oxygen, are impact sensitive and can detonate if subjected to shock.

### **Keep Area and Exterior Surfaces Clean to Prevent Ignition**

As normal industrial soot and dirt can constitute a combustion hazard, all equipment surfaces must be kept very clean. Do not place oxygen equipment on asphalt surfaces, or allow grease or oil deposits to remain on benches or concrete surfaces in the vicinity of the oxygen equipment. Use cleaning agents, which will not leave organic deposits on the cleaned surfaces. Equipment to be used in contact with liquid oxygen should be handled only with clean gloves or hands washed clean of oil.

### **Maintain Adequate Ventilation**

Enclosed areas containing oxygen equipment should be ventilated to prevent accumulations of oxygen and thereby minimize combustion hazards.

### **Extreme Cold - Cover Eyes and Exposed Skin**

Accidental contact of liquid oxygen or cold issuing gas with the skin or eyes may cause a freezing injury similar to frostbite. Handle the liquid so that it won't splash or spill. Protect your eyes and cover the skin where the possibility of contact with the liquid, cold pipes and cold equipment, or the cold gas exists. Safety goggles or a face shield should be worn if liquid ejection or splashing may occur or cold gas may issue forcefully from equipment. Clean, insulated gloves that can be easily removed and long sleeves are recommended for arm protection. Cuffless trousers should be worn outside boots or over the shoes to shed spilled liquid. If clothing should be splashed with liquid oxygen or otherwise saturated with the gas, air out the clothing immediately, removing it if possible. Such clothing will be highly flammable and easily ignited while the concentrated oxygen remains, and should not be considered safe for at least 30 minutes.

### **Replacement Parts Must be Suitable for Oxygen Service**

Many materials, especially some non-metallic gaskets and seals, constitute a combustion hazard when in oxygen service, although they may be acceptable for use with other cryogenic liquids. Make no substitutions for recommended spare parts. Also, be sure all replacement parts are thoroughly "Cleaned For Oxygen Service" in accordance with Compressed Gas Association (CGA) Pamphlet G-4.1 "Cleaning for Oxygen Service" or equivalent industrial cleaning specifications.

### **Observe Safety Codes When Locating Oxygen Equipment**

Before locating oxygen equipment, become thoroughly familiar with National Fire Protection Association (NFPA) Standard No. 50, "Bulk Oxygen Systems", and with all federal, state and local safety codes. The NFPA Standard covers the general principles recommended for the installation of bulk oxygen systems on industrial and institutional consumer premises.

**CAUTION: When installing field fabricated piping, make certain a suitable safety valve is installed in each section of piping between shut-off valves.**

For more detailed information concerning safety precautions and safe practices to be observed when handling cryogenic liquids consult CGA pamphlet P-12 "Handling Cryogenic Liquids" available from the Compressed Gas Association, 1235 Jefferson Davis Highway, Arlington, Va. 22202.

## **SAFETY PRECAUTIONS FOR LIQUID NITROGEN**

Nitrogen is an inert, colorless, odorless, and tasteless gas, which makes up four-fifths of the air you breathe. Liquid nitrogen is obtained by cooling air until it becomes a liquid and then removing the oxygen, which makes up the other fifth of the air. Liquid nitrogen is at a temperature of 320 degrees below zero Fahrenheit (-196°C) under normal atmospheric pressure.

### **Extreme Cold - Cover Eyes and Exposed Skin**

Accidental contact of liquid nitrogen or cold issuing gas with the skin or eyes may cause a freezing injury similar to frostbite. Handle the liquid so that it won't splash or spill. Protect your eyes and cover the skin where the possibility of contact with the liquid, cold pipes and cold equipment, or the cold gas exists. Safety goggles or a face shield should be worn if liquid ejection or splashing may occur or cold gas may issue forcefully from equipment. Clean insulated gloves that can be easily removed and long sleeves are recommended for arm protection. Cuffless trousers should be worn outside boots or over the shoes to shed spilled liquid.

### **Keep Equipment Area Well Ventilated**

Although nitrogen is non-toxic and non-flammable, it can cause asphyxiation in a confined area without adequate ventilation. Any atmosphere, which does not contain enough oxygen for breathing, can cause dizziness, unconsciousness, or even death. Nitrogen being colorless, odorless, and tasteless cannot be detected by the human senses and will be inhaled normally as if it were air. Without adequate ventilation, the expanding nitrogen will displace the normal air without warning that a non-life-supporting atmosphere is present. Store liquid containers outdoors or in other well-ventilated areas.

### **Dispose of Waste Liquid Nitrogen Safely**

Dispose of waste liquid nitrogen out-of-doors where its cold temperature cannot damage floors or driveways and where it will evaporate rapidly. An outdoor pit filled with clean sand or gravel will evaporate liquid nitrogen safely and quickly.

**CAUTION: When installing field fabricated piping, make certain a suitable safety valve is installed in each section of piping between shut-off valves.**

For more detailed information concerning safety precautions and safe practices to be observed when handling cryogenic liquids consult CGA pamphlet P-12 "Handling Cryogenic Liquids" available from the Compressed Gas Association, 1235 Jefferson Davis Highway, Arlington, VA 22202.

**NOTE:** Argon is an inert gas whose physical properties are very similar to those of nitrogen. For handling of liquid argon, follow the safe practices described for the handling and use of liquid nitrogen.

## **INTRODUCTION**

This manual provides information for the user to operate and maintain Taylor-Wharton's VT-250 model cryogenic storage tanks which can be supplied with Final Piping Package Options 1, 2, 3, or 4. These tanks are suitable for the storage and delivery of liquid oxygen, nitrogen or argon at a maximum allowable working pressure of 250 psig (17.24 bar/1724 kPa). They are also suitable for the delivery of gaseous product when combined with a vaporizer, standard on VT-1500, Piping Options 2 and 4.

Tank specifications, flow diagram and an elevation with bottom view of the tank showing controls and piping may be found on the General Arrangement Drawings located in the back of this manual. Additional copies of these drawings may be obtained from the factory. Please include information on the tank model number and part number in making drawing requests. Tank Specifications, Rigging Details and Vacuum System Components are also shown in this manual.

## **FUNCTIONAL DESCRIPTION**

### ***TANK CONSTRUCTION***

The VT-250 tanks are vertical tanks with a maximum allowable working pressure of 250 psig (17.24 bar/1724 kPa). The pressure vessel is suspended inside a vacuum jacket and insulated with perlite powder under high vacuum. The liquid and gas phase lines to the pressure vessel pass through the lower head of the vacuum jacket. All piping is designed to withstand the stresses caused by expansion and contraction of the pressure vessel, its support system and piping itself.

The pressure vessel is designed and constructed in accordance with the ASME Boiler and Pressure Vessel Code Section VIII, Division 1. The inner vessel is constructed of 9% nickel steel or stainless steel, and the piping is stainless steel. The vacuum jacket and leg supports are made of structural steel.

The insulation space between the pressure vessel and the vacuum jacket is filled with perlite powder insulation and evacuated to a high vacuum through a VACUUM PUMPOUT VALVE (HCV-6) that is permanently sealed at the factory. Insulation space vacuum is measured in the field by connecting a vacuum gauge to the VACUUM PROBE (VR-1), which is located on the lower head of the tank. The VACUUM PROBE (VR-1) is isolated from the vacuum jacket by a VACUUM PROBE ISOLATION VALVE (HCV-5).

### ***PIPING***

The following paragraphs describe the operation of the main circuits of the VT-250 bulk tanks. The descriptions refer to the main components of each circuit and are grouped by function. These component and circuit descriptions are pertinent to any of the VT-250 tanks and should be read before attempting operation.

## **Fill**

The tank is filled with liquid through the FILL CONNECTION (CN-1), FILL LINE CHECK VALVE (CV-1), and FILL VALVES (HCV-1) and (HCV-2). One FILL VALVE (HCV-2) is connected to the top of the pressure vessel and other (HCV-1) is connected to the bottom of the of the pressure vessel. Filling through the TOP FILL VALVE (HCV-2) tends to reduce tank pressure, while filling through the BOTTOM FILL VALVE (HCV-1) tends to increase tank pressure.

TANK BLOWDOWN VALVE (HCV-12) can be opened for venting and throttled to maintain desired tank pressure during filling.

FILL LINE CHECK VALVE (CV-1) prevents flow out of the tank through the fill connection in the event of a misconnection or broken line.

FILL LINE DRAIN VALVE (HCV-7) is used to vent the fill line during fill hose cool-down, and to drain liquid product trapped between the fill connection and the fill valves after a fill is completed.

THERMAL EXPANSION RELIEF VALVE (TSV-2) will relieve pressure in the fill line that may result from expanding residual liquid trapped between the FILL LINE CHECK VALVE (CV-1) and the BOTTOM and TOP FILL VALVES (HCV-1, HCV-2).

The TRYCOCK VALVE (HCV-4) is used to determine fill termination.

## **Withdrawal and Economizer**

During operation when the tank pressure is below the set point of ECONOMIZER BACK PRESSURE REGULATOR (PCV-2) liquid product is withdrawn through the siphon withdrawal line and PRODUCT SUPPLY VALVE (HCV-13). When tank pressure exceeds the set point of ECONOMIZER BACKPRESSURE REGULATOR (PCV-2), and ISOLATION VALVES (HCV-11) and (HCV-14) are open gas will flow from the top of the tank through PRESSURE BUILDING ISOLATION VALVE (HCV-11), ECONMOMIZER ISOLATION VALVE (HCV-14), and ECONOMIZER REGULATOR (PCV-2). From (PCV-2) the gas flows back in the annular space economizer line that connects to the siphon withdrawal line, and finally exits through PRODUCT SUPPLY VALVE (HCV-13). When installed external vaporizers are normally connected to PRODUCT SUPPLY VALVE (HCV-13).

AUXILIARY LIQUID WITHDRAWAL CONNECTION (CN-3) and AUXILIARY LIQUID LINE (C) provide liquid only withdrawal from the tank.

VAPOR LINE (J) is the point where vapor product can be returned to the tank from a pump.

The THERMAL EXPANSION RELIEF VALVE (TSV-4) will relieve pressure buildup from trapped product between ECONOMIZER ISOLATION VALVE (HCV-14) and ECONOMIZER BACK PRESSURE REGULATOR (PCV-2).

## **Pressure Building**

The pressure building system provides a means of maintaining tank pressure at a preset value during product withdrawal. This system operates when PRESSURE BUILDING ISOLATION VALVES (HCV-3) and (HCV-11) are open. When tank pressure decreases to the PRESSURE BUILDING REGULATOR (PCV-1) setpoint, it opens and liquid flows from the bottom of the tank through PRESSURE BUILDING COIL (PBC-1). This liquid product is vaporized in the coil and expanded gaseous product returns to the top of the tank maintaining tank pressure. When tank pressure increases above the regulator's set point it closes and the pressure building process stops.

The THERMAL EXPANSION RELIEF VALVE (TSV-3) will relieve pressure buildup from trapped liquid between the pressure building regulator and the inlet valve.

### **Safety Devices**

The tank vacuum jacket is protected from overpressure by the VACUUM JACKET LIFT PLATE (PSE-3).

Overpressure protection for the pressure vessel is provided by dual TANK PRESSURE RELIEF VALVES (PSV-1A, PSV-1B) and RUPTURE DISCS (PSE-1A, PSE-1B). The pressure relief valves provide primary protection for the inner vessel; the rupture disks are secondary safety devices. A RELIEF SYSTEM DIVERTER VALVE (HCV-15) permits the operation of one set of protection devices while the other set is isolated. This arrangement prevents both sets of safety devices from being isolated from the tank at the same time and permits maintenance of the devices without the need to vent tank pressure. Either one of two types of diverter valves may be installed on the tank.

*Tanks equipped with diverter ball valves (options 2 & 3):* To activate one set of devices while isolating the other move the selector valve handle all the way to the end of its travel toward the devices to be activated.

*Tanks equipped with diverter globe valve (options 1 & 4):* Turn the RELIEF SYSTEM DIVERTER VALVE (HCV-15) handle counterclockwise (in direction of arrow on hand wheel) to the end of its travel to open port #1 and to close port #2 for servicing the relief devices. Likewise, turn the handle clockwise to the end of its travel to open #2 and close port #1 for servicing.

Line THERMAL EXPANSION RELIEF VALVES (TSV-2, 3, and 4) are installed in the tank external piping at points where liquid or cold gas could become trapped.

### **Instrumentation**

*Final Piping Options 1, 2, and 4:* - Tank pressure is indicated by a tank PRESSURE GAUGE (PI-1). Liquid level is indicated on the LIQUID LEVEL GAUGE (LI-1). Piping with LIQUID LEVEL GAUGE ISOLATION VALVES (V-8) & (V-10) and an EQUALIZATION VALVE (V-9) connect the gauges to the tank. The LIQUID LEVEL GAUGE (LI-1) is calibrated in inches of water and a conversion chart located next to the liquid level gauge is used to convert the gauge reading to volume of liquid.

*Final Piping Option 3:* - Liquid level and pressure indicating devices are not supplied on Final Piping Option 3. VAPOR PHASE ISOLATION VALVE (HCV-8) is connected to a pressure tap

that is attached to the top of the pressure vessel. LIQUID PHASE ISOLATION VALVE (HCV-10) is connected to a pressure tap attached to the bottom to the pressure vessel. These connections provide the customer a means of connecting a differential pressure gauge to determine liquid level and a pressure gauge to determine tank pressure. When installed the differential pressure gauge's high-pressure port will be connected to (HCV-10), the low-pressure port will be connected to (HCV-8), and a bypass valve connecting the instrument lines should be installed between the isolation valves and the device. During operation this bypass valve will remain closed; its function being to equalize the pressure on each side of the differential pressure gauge. The pressure gauge will be connected to (HCV-8) so that pressure at the top of the vessel is measured.

Standard on Final Piping Option 2 a LIQUID LEVEL GAUGE (LI-1) with electrical switches is available on other options for installations requiring low and high level warnings. The gauge switches can be wired to sound an alarm or light indicator lamps on either low or high tank liquid level.

### **Vacuum System**

Several tank components are provided for vacuum system maintenance. The VACUUM PUMPOUT VALVE (HCV-6) is the port used to pump air from the tank insulation space. It is normally blanked-off and never opened unless the tank requires a field re-evacuation after a repair. The VACUUM PROBE (VR-1) is a thermocouple that is installed to allow connection of a vacuum gauge to measure the quality of the vacuum in the insulation space. The VACUUM PROBE ISOLATION VALVE (HCV-5) is opened during vacuum measurement to expose the vacuum probe sensors to the tank insulation space. This valve is normally closed to protect the integrity of the vacuum and insulation.

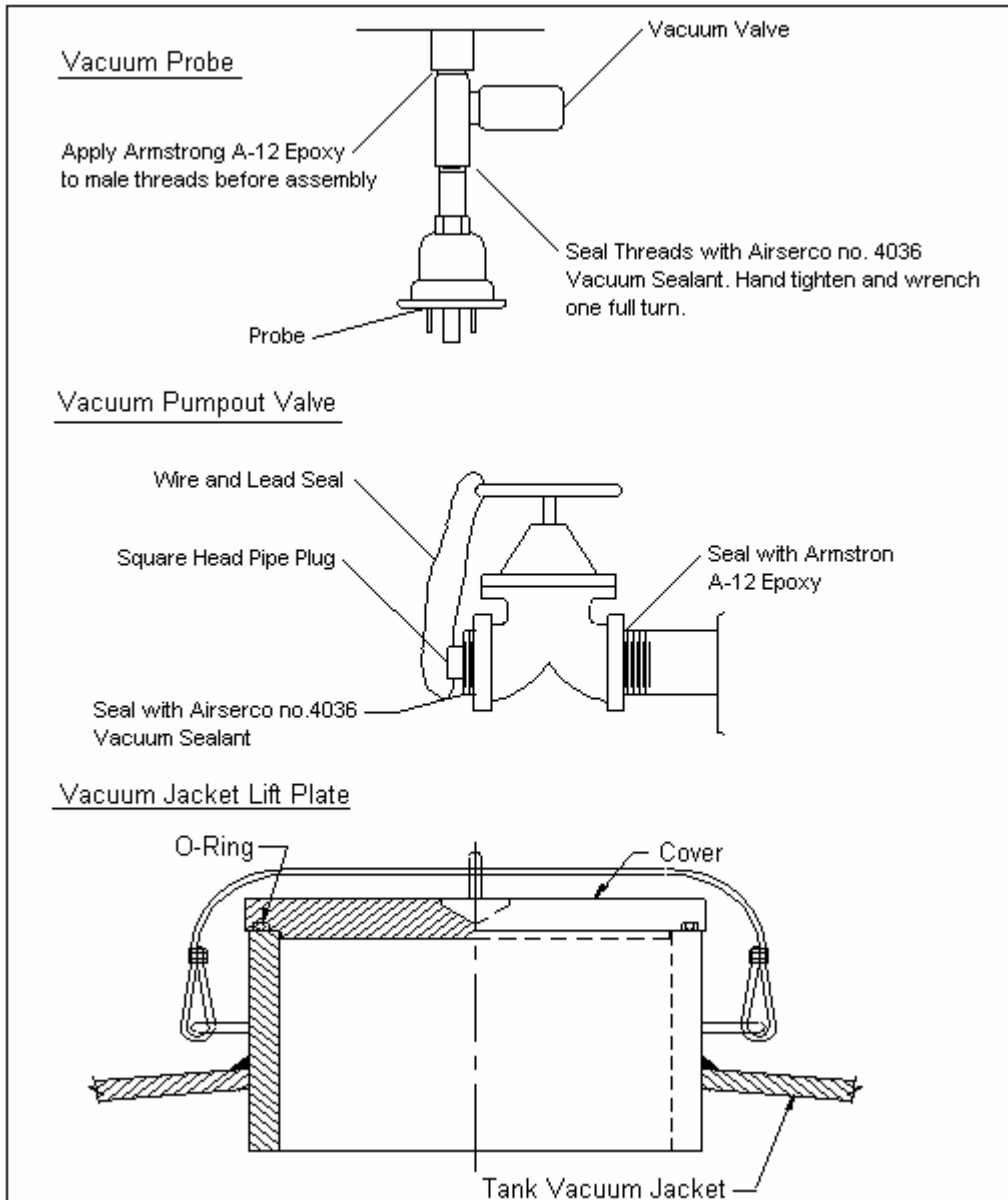

Vacuum System Components

## INSTALLATION

### *HANDLING*

Dimension and connection data for the VT-250 tanks can be found on the applicable General Arrangement Drawing in this manual. Additional copies of these drawings may be requested from the factory. Please include information on the tank model number and part number in making requests for this drawing. The drawing part number is listed in the applicable Specification chart in this manual.

Tank installation is the customer's responsibility. The tank is shipped in the horizontal position. If the tank is secured on temporary wooden cradles, the cradles must be removed prior to erection of the tank. Make certain the foundation used for the tank is designed for the conditions at the installation site, and that it is suitable for the tank weight. Refer to local codes for recommended foundation specifications. Employ experienced personnel to move and install the tank. Ensure that

rigging equipment has adequate rated capacity to handle the tank weight listed in the specifications. This tank must be shipped and lifted empty, and with a warm inner vessel.



*To prevent possible tip over, do not leave the tank standing upright unless it is on a specified foundation or other hard surface capable of supporting its weight. Loading on the tank legs is great enough to cause them to sink into most surfaces other than reinforced concrete.*

### ***INSTALLATION CHECKS***

Before off-loading the tank, inspect it carefully for possible shipping damage. Report any damage to the carrier and the factory. In addition, check tank pressure and vacuum as follows:

1. Tanks are shipped pressurized with nitrogen gas at 20 psig (1.38 bar/138 kPa). Open the gauge VAPOR PHASE ISOLATION VALVE (HCV-8) and read tank pressure indicated on PRESSURE GAUGE (PI-1) or a pressure gauge installed by user. Record the "as received" tank pressure. Close the VAPOR PHASE ISOLATION VALVE (HCV-8).

Tank pressure may change due to temperature variations, accidental opening of valves, packing leaks, or minor leaks at the FILL CONNECTION (CN-1). If a positive pressure is not indicated on the pressure gauge and no repairable leaks are found, contact the factory in accordance with conditions specified in the tank warranty.

2. Check insulation space vacuum by connecting a Hasting-Raydist Model TV-4A or VT-6 vacuum gauge to the tank VACUUM PROBE (VR-1). Open the tank VACUUM PROBE ISOLATION VALVE (HCV-5), wait 30 minutes, and take a reading. If the "as received" vacuum (tank at ambient temperature) is greater than 250 microns (0.25 mm Hg) absolute, contact the factory.
3. Attach a tag to the tank at the FILL CONNECTION (CN-1) indicating the normal operating pressure range of the tank. This information enables an operator to monitor tank pressure during a tank fill and prevents pressure upsets caused by improper fill procedures.

### ***CUSTOMER INSTALLED EQUIPMENT***

Designing safe and effective cryogenic systems requires extensive knowledge and experience. Persons lacking the necessary skills are urged to seek competent advice before attempting to design cryogenic system.

When installing vaporizing and control equipment, be sure to follow accepted design practices for cryogenic equipment. All equipment must be cleaned for oxygen service. Be sure to include pressure relief valves in piping where product could be trapped between closed valves, regulators, etc. and cause over-pressurization due to fluid expansion.

## **Requirements for Installation and Use Within New York City Fire Department Jurisdiction**

Owners and installers within NYCFD jurisdiction are required to meet the following guidelines concerning the installation and use of VT-250 design bulk tanks.

- The installation and use of the vessel must comply with all applicable New York City Codes, Rules, and Regulations.
- After installation, the vessel shall not be filled until the required New York City Fire Department storage permit has been issued.
- The owner / installer shall be in compliance with all of the manufacturer's installation and maintenance procedures and limitations.
- The liquid level gauge is to be marked to indicate the maximum permissible fill level for the respective gas being utilized.
- The vessel fill capacity shall be limited to comply with CGA-341 (Standard for Insulated Cargo Tank Specification for Cryogenic Liquids).
- The vessel is for outdoor use only, will be placed in areas acceptable to NYCFD, and must be protected from vandalism.
- Changes in ownership or owner's name must be reported to NYCFD in writing.

**WARNING: Failure to comply with the conditions of Certificate of Approval #4956 can be the basis for being subjected to enforcement action that can include fines and imprisonment.**

# RIGGING

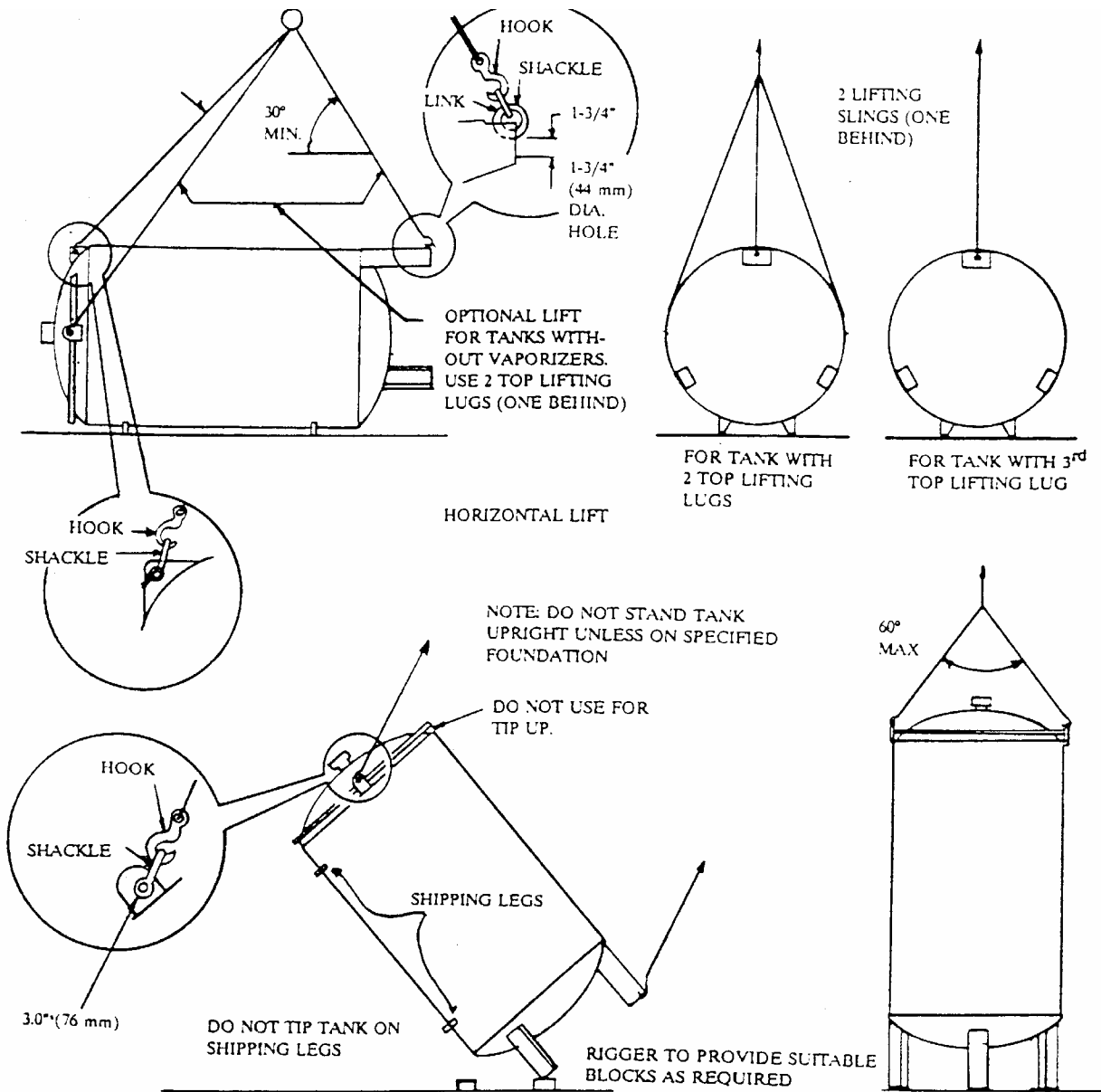

Note: Refer to General Arrangement Drawing for Critical Weight and Dimensional Data

Figure 1: Rigging for VT-1500 and VT-3000

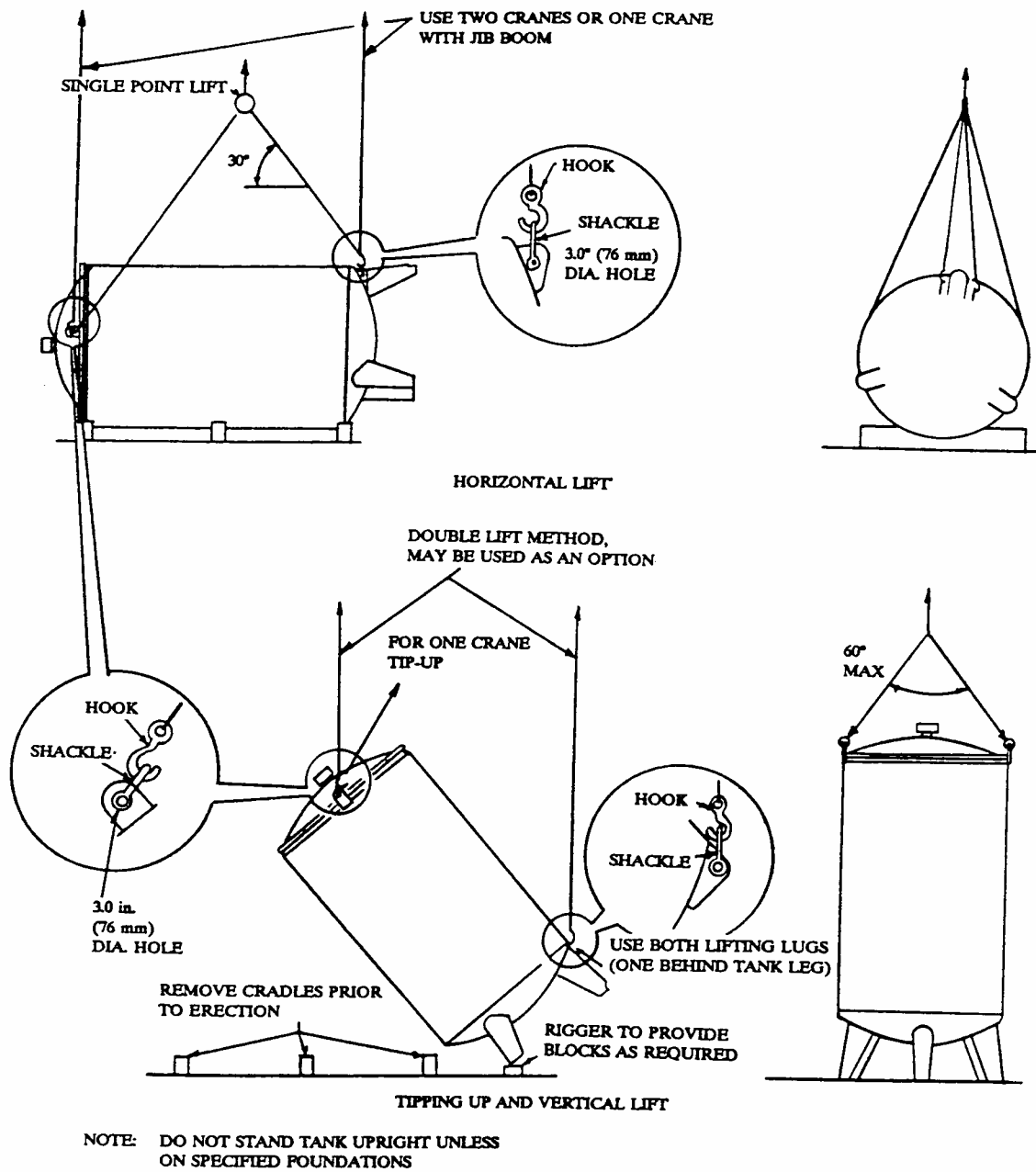

Note: Refer to General Arrangement Drawing for Critical Weight and Dimensional Data

Figure 1: Rigging for VT-6000 through VT-13000

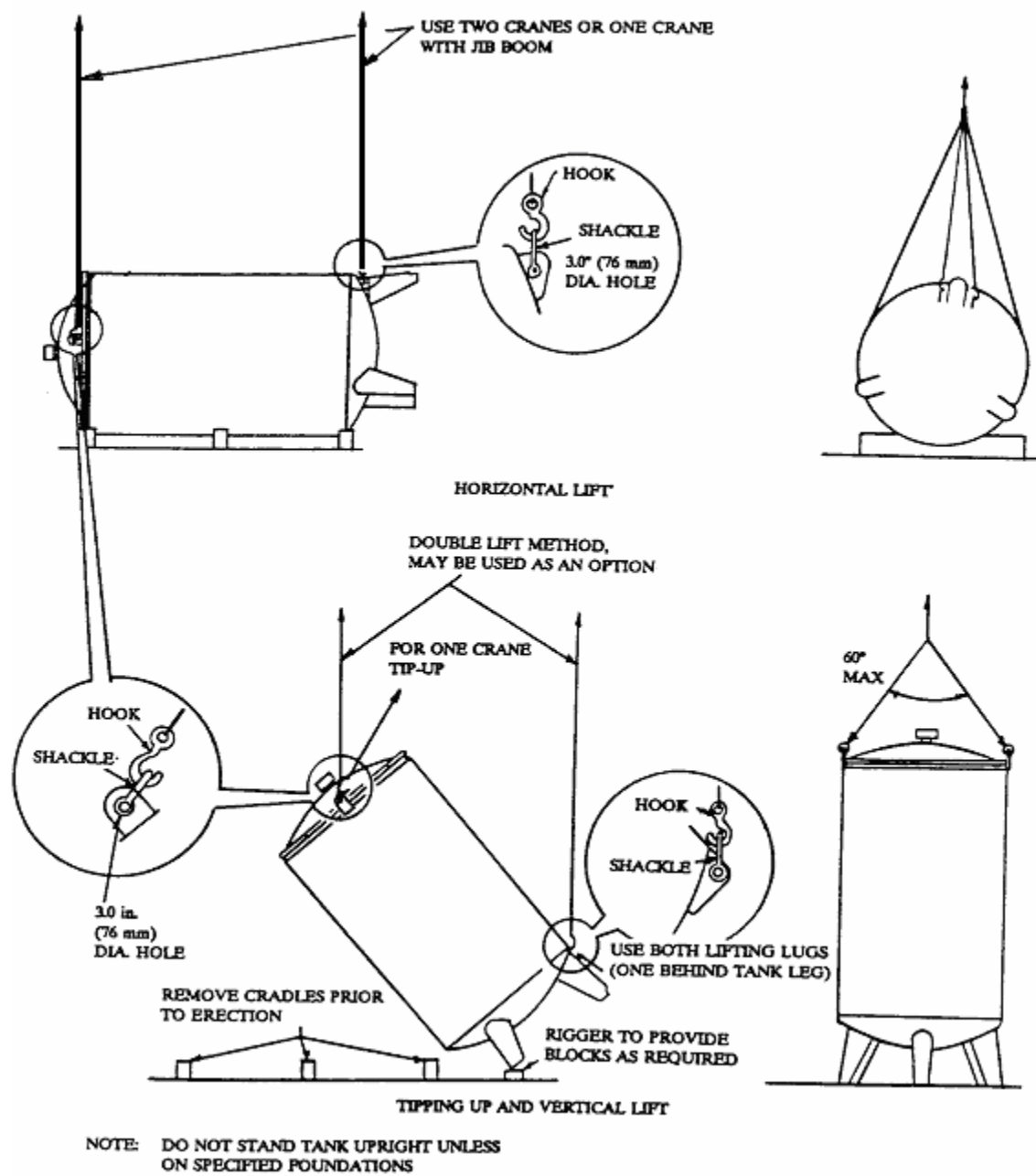

Note: Refer to General Arrangement Drawing for Critical Weight and Dimensional Data

Figure 1: Rigging for VT-15000

## OPERATION

These instructions are for experienced operators. Before operating the storage tank become thoroughly familiar with the safety precautions in this manual and in reference publications. Make certain all applicable provisions set forth in the Installation section have been followed before placing a tank in operation. Study the Flow Diagram, Tank Elevation and End Views on the applicable General Arrangement Drawing located in the back of this manual and the Functional Description section of this manual. Know the location and function of all tank components.

### ***PURGE PROCEDURE***

Before placing a tank in service, determine the level of purity in the pressure vessel. If pressure vessel contents purity is unacceptable, perform a product purge to reduce contaminants. The following procedure is recommended for most application:

1. Attach the liquid purge product source to tank FILL CONNECTION (CN-1). Product delivery pressure should be approximately 100 psig (6.9 bar/690 kPa).



A positive pressure must always be maintained in the tank during the purge procedure to prevent drawing atmospheric contaminants back into the tank.

2. Close all valves except ISOLATION VALVES (HCV-8, HCV-10), PRESSURE BUILDING ISOLATION VALVE (HCV-3), and PRESSURE BUILDING ISOLATION VALVE (HCV-11).
3. Open TANK BLOWDOWN VALVE (HCV-12) and vent inner vessel to 5 psig (0.34 bar/34 kPa) as indicated on the tank PRESSURE GAUGE, INNER VESSEL (PI-1). If not supplied with the tank this PRESSURE GAUGE, INNER VESSEL must be installed by the Customer. Close TANK BLOWDOWN VALVE (HCV-12).
4. Open BOTTOM FILL VALVE (HCV-1) slightly to allow liquid to flow slowly into bottom of tank. Flow must be gradual enough to allow the liquid to vaporize in the bottom fill line and PRESSURE BUILDING COIL (PBC-1) so the pressure builds up in the inner vessel. Momentarily open TOP FILL VALVE (HCV-2) to flood the exposed section of line, then close valve.
5. When tank PRESSURE GAUGE, INNER VESSEL (PI-1) indicates maximum desired purge pressure, close the liquid supply source. Close PRESSURE BUILDING ISOLATION VALVE (HCV-3).
6. Cautiously drain liquid from the tank by opening the AUXILIARY LIQUID VALVE (HCV-17) if provided or through the FILL LINE HOSE DRAIN VALVE (HCV-7). The valve should be opened slowly to avoid splashing of liquid. When vapor appears from the valve, the liquid has been drained from the tank.
7. Close AUXILIARY LIQUID VALVE (HCV-17) or FILL LINE HOSE DRAIN VALVE (HCV-7) opened in step 6.

8. *Tanks with factory supplied LIQUID LEVEL GAUGE:* - After liquid has drained from the tank, close ISOLATION VALVES (HCV-8, HCV-10). The EQUALIZATION VALVE (HCV-9) should be opened just before closing ISOLATION VALVES (HCV-8, HCV-10) to prevent damage to the LIQUID LEVEL GAUGE (LL-1). Carefully loosen the adapters on both sides of the LIQUID LEVEL GAUGE to relieve pressure. Disconnect the instrument lines and fully open ISOLATION VALVES (HCV-8, HCV-10). Visually check the resultant gas streams for signs of moisture. Vent lines for approximately two minutes. If no moisture is evident, close the ISOLATION VALVES (HCV-8, HCV-10). If moisture is evident, continue venting until the stream is free of moisture.

*Tanks without factory supplied LIQUID LEVEL GAUGE:* - Prior to installing components to ISOLATION VALVES (HCV-8, HCV-10) visually check the resultant gas streams for signs of moisture by fully opening ISOLATION VALVES (HCV-8, HCV-10). Vent lines for approximately two minutes. If no moisture is evident, close ISOLATION VALVES (HCV-8, HCV-10). If moisture is evident, continue venting until the stream is free of moisture.

 **CAUTION:** Do not look directly into the tank lines. Bodily injury could occur.

*NOTE:* Carefully open gauge valves since some residual liquid may have remained in tank or the instrument lines.

9. Open PRODUCT SUPPLY VALVE (HCV-13) and AUXILIARY LIQUID VALVE (HCV-17) if provided to check for moisture as in Step 8.
10. Open TANK BLOWDOWN VALVE (HCV-12) and TRYCOCK VALVE (HCV-4) and check for moisture as in step 8.
11. Repeat purge procedures 2 through 11 until acceptable product purity is achieved.
12. Reconnect the LIQUID LEVEL GAUGE (installed by user), open ISOLATION VALVES (HCV-8, HCV-10) and close EQUALIZATION VALVE (installed by user).
13. After completion of tank purge, make sure that all valves are closed except the GAUGE ISOLATION VALVES (HCV-8, HCV-10).

### ***FILLING A WARM TANK***

Perform the following steps to fill a tank for the first time or when returning a tank to service after it has been emptied and allowed to warm.

1. Close all valves except GAUGE ISOLATION VALVES (HCV-8) and (HCV-10).
2. Check the name of the contents on the supply source against the product name on the tank to be certain that the proper product is being transferred into the tank.
3. Connect supply source fill hose to tank FILL CONNECTION (CN-1). Make certain connection is leak tight. Purge the fill hose.

**NOTE:** The tank was pressurized at the factory with nitrogen gas. Before the tank is to be filled with any product, it must be purged with product until analysis indicates an acceptable purity. Use the steps outlined in the Purge Procedure section above as a guide.

4. Open TANK BLOWDOWN VALVE (HCV-12) and TRYCOCK VALVE (HCV-4). Vent tank pressure to about 5 psig (0.34 bar/34 kPa). Close the TANK BLOWDOWN VALVE (HCV-12) but leave the TRYCOCK VALVE (HCV-4) open.
  5. Fully open TOP FILL VALVE (HCV-2) and PRESSURE BUILDING ISOLATION VALVE (HCV-11) to fill tank as rapidly as possible.
  6. Monitor tank pressure on tank PRESSURE GAUGE, INNER VESSEL (PI-1). If tank pressure rises to within 90% of tank RELIEF VALVE (PSV-1A/1B) setting, close tank TOP FILL VALVE (HCV-2) and stop fill immediately. Open TANK BLOWDOWN VALVE (HCV-12) and vent tank pressure to at least 50 psig (3.45 bar/345 kPa) below RELIEF VALVE (PSV-1A/1B) set point. Close the TANK BLOWDOWN VALVE (HCV-12). Open tank TOP FILL VALVE (HCV-2) and resume filling.
  7. When liquid spurts from tank TRYCOCK VALVE (HCV-4), close supply source valve to stop fill. Close tank TRYCOCK VALVE (HCV-4).
  8. When residual liquid in the fill hose vaporizes, close tank TOP FILL VALVE (HCV-2).
-  **CAUTION:** To avoid injury, do not touch fill hose or connections with bare hands. During filling, these parts are cooled to extremely low temperatures.
9. Open FILL LINE DRAIN VALVE (HCV-7) to relieve fill hose pressure. Close FILL LINE DRAIN VALVE (HCV-7).
  10. When pressure is released disconnect fill hose.
  11. Close valve PRESSURE BUILDING ISOLATION VALVE (HCV-11).

### ***FILLING A COLD TANK***

Perform the following steps to fill a tank containing liquid product or one that has been recently emptied, but still cold.

**NOTE:** Make certain the FILL VALVES (HCV-1) and (HCV-2) are closed.

1. Check the name of the contents on the supply source against the product name on the tank to be sure that proper product is being transferred into the tank.
2. Connect supply source fill hose to tank FILL CONNECTION (CN-1). Make certain connection is leak tight. Purge fill hose.
3. Open supply source liquid delivery valve.

4. Fully open tank BOTTOM FILL VALVE (HCV-1), PRESSURE BUILDING ISOLATION VALVES (HCV-3) & (HCV-11) start tank fill. Open tank TOP FILL VALVE (HCV-2) one turn. Adjust the two FILL VALVES (HCV-1, HCV-2) as required to maintain normal tank operating pressure as shown on tag attached to tank PRESSURE GAUGE, INNER VESSEL (installed by user).

NOTE: Filling through the BOTTOM FILL VALVE (HCV-1) will increase tank pressure since gas in the vapor space is compressed, whereas filling through the TOP FILL VALVE (HCV-2) decreases tank pressure since gas in the ullage space is cooled and re-liquefied.

5. Open tank FULL TRYCOCK valve (HCV-4) when tank LIQUID LEVEL GAUGE (supplied by customer) indicates 3/4 full.
6. When liquid spurts from tank FULL TRYCOCK VALVE (HCV-4), close supply source delivery valve to stop fill. Close tank BOTTOM FILL VALVE (HCV-1) and FULL TRYCOCK valve (HCV-4).
7. When residual liquid in the fill hose vaporizes, close tank TOP FILL VALVE (HCV-2).

**CAUTION: To avoid injury, do not touch fill hose or connections with bare hands. During filling, these parts are cooled to extremely low temperatures.**

8. Open FILL LINE DRAIN VALVE (HCV-7) to relieve fill hose pressure. Close FILL LINE DRAIN VALVE (HCV-7).
9. When pressure is released disconnect fill hose.

### ***NORMAL OPERATION***

During normal operation, tank pressure forces product through the siphon withdrawal line and the VAPORIZER INLET VALVE (HCV-13) to an external vaporizer that feeds the user's pipeline. To compensate for lowering of tank pressure as product is withdrawn, the PRESSURE BUILDING REGULATOR (PCV-1) allows a regulated amount of liquid to flow to the PRESSURE BUILDING COIL (PBC-1). Vaporized liquid is returned to the tank to provide the driving force for uninterrupted pipeline withdrawal. During periods when the withdrawal rate is low and tank pressure rises above the set point of ECONOMIZER REGULATOR (PCV-2), the economizer circuit becomes operational. Liquid withdrawal is interrupted and gas flows through the ECONOMIZER REGULATOR (PCV-2) to the vaporizer thereby supplying the pipeline with gas that would otherwise be vented to the atmosphere.

To prepare the tank for normal product withdrawal, open the following valves:

PRESSURE BUILDING ISOLATION VALVE (HCV-11),

PRESSURE BUILDING ISOLATION VALVE (HCV-3),

## LIQUID LEVEL GAUGE ISOLATION VALVES (HCV-8) & (HCV-10)

## PRODUCT SUPPLY VALVE (HCV-13),

All other valves should be closed.

### ***TAKING A TANK OUT OF SERVICE***

Schedule shutdown operation to coincide with low liquid level in the tank. If a large quantity of liquid is in the tank, drain it into a trailer for use elsewhere or for disposal at a safe location. For tanks so equipped, small quantities of liquid can be vaporized by the PRESSURE BUILDING COIL (PBC-1) and vented through the TANK BLOWDOWN VALVE (HCV-12), provided appropriate safety precautions are taken.

For shutdowns of short duration, retain residual liquid in the tank. Close all valves except tank LIQUID LEVEL GAUGE ISOLATION VALVES (HCV-8) and (HCV-10).

For shutdowns of a prolonged duration, perform the following steps.

### ***TANKS IN OXYGEN SERVICE***

1. Drain liquid from tank. Open the TANK BLOWDOWN VALVE (HCV-12) and reduce tank pressure to atmospheric. Close the TANK BLOWDOWN VALVE (HCV-12).
2. Connect a source of warm nitrogen gas to tank FILL CONNECTION (CN-1). Admit nitrogen purge gas through tank BOTTOM FILL VALVE (HCV-1). Vent tank through the TANK BLOWDOWN VALVE (HCV-12). Two or three times during purge, close the TANK BLOWDOWN VALVE (HCV-12) and build tank pressure to about 10 psig (0.7 bar/70 kPa). Release pressure and continue purge.
3. Open the tank TRYCOCK VALVE (HCV-4) and the PRESSURE BUILDING ISOLATION VALVE (HCV-3) and check exit gas with a nitrogen gas analyzer. Allow one hour between samples reading for the gas to adequately mix. Discontinue purge when only nitrogen gas is indicated. Close tank TRYCOCK VALVE (HCV-4).
4. Close the TANK BLOWDOWN VALVE (HCV-12). Build tank pressure to 20 psig (1.38 bar/138 kPa). Close tank BOTTOM FILL VALVE (HCV-1). Disconnect nitrogen gas hose from tank FILL CONNECTION (CN-1).
5. Warm tank inner vessel before shipping to a new location.

### ***TANKS IN NITROGEN/ARGON SERVICE***

1. Drain liquid product from tank. Open tank TANK BLOWDOWN VALVE (HCV-12) and reduce tank pressure to 20 (1.4 bar/140 kPa). Close tank TANK BLOWDOWN VALVE (HCV-12).
2. Warm tank inner vessel before moving to a new location.

## MAINTENANCE

### *GENERAL*

The need for maintenance usually becomes apparent from inspection of the tank before filling, routine observation during and after filling, and indications of improper operation. Typical trouble indications would be unusually high or low tank or pipeline pressure, leakage from valves or piping connections, and excessive venting through relief valves. Prompt action to correct damage or malfunction is required to assure reliable operation. Keep a permanent log of all inspections, vacuum readings, and repairs performed. Such a log can be valuable in evaluating tank performance and scheduling maintenance.

Always observe the safety precautions at the front of this manual and follow the instructions given in this section. Before working on the tank or piping system, isolate the piping section to be repaired from the tank, and relieve pressure on the component or piping.

Do not allow unqualified persons to attempt repairs on this equipment. Field repairs to instruments and controls must be made by a qualified instrument specialist. Refer to the Trouble-Remedy Guide in this manual for assistance in troubleshooting.

Make certain all parts that will come in contact with cryogenic liquid or gaseous product have been cleaned for in conformance with CGA Pamphlet G-4.1, "Cleaning Equipment for Oxygen Service", or other equivalent standard. If parts are purchased cleaned for oxygen service, they should be suitably packaged to prevent contamination.

### *LEAK TESTING*

After making repairs requiring disassembly or part replacement, leak test all valves or piping joints that were taken apart and reconnected. Apply the leak detector to the test surface per the manufacturer's instructions. Large leaks instantly form large bubble clusters, while fine leaks produce white foam that builds up more slowly. All leaks must be repaired and retested before the tank is returned to service.

**WARNING: For O<sub>2</sub> System Users: Residue of leak detectors can be flammable. All surfaces to which the leak detector solutions have been applied must be adequately rinsed with potable water to remove all traces of residue. Reference CGA G-4. Section 4.9.**

### *HAND VALVES*

The most common trouble with manual valves will be leakage at the stem packing. Packing leaks are usually indicated by frost or ice accumulation more than half way up the valve stem extension. If packing leakage cannot be stopped by tightening, add or replace packing. Use preformed packing, which can be ordered from the valve manufacturer.

Standard maintenance practices apply to the replacement of seats and discs in globe and gate valves. Replacement parts may be ordered from the valve manufacturer. Provide the factory part number marked on the valve for identification.

## ***CONTROL VALVES***

These tanks have two automatic valves that control operating pressures.

The PRESSURE BUILDING REGULATOR (PCV-1) opens on falling tank pressure and closes on rising pressure. This valve is factory set at 150 psig (10.34 bar/1034 kPa).

The ECONOMIZER BACK PRESSURE REGULATOR (PCV-2) is a backpressure device that opens on rising tank pressure and closes on falling pressure. This valve is factory set at 165 psig (11.37 bar/1137 kPa).

The factory setting of the control valves may be field adjusted. The ECONOMIZER BACK PRESSURE REGULATOR (PCV-2) should be set to open at a pressure above the shut-off pressure of the pressure building circuit.

Before attempting repair of either of the control valves, isolate and depressurize the valves by closing the PRESSURE BUILDING ISOLATION VALVE (HCV-3), PRESSURE BUILDING ISOLATION VALVE (HCV-11) and ECONOMIZER ISOLATION VALVE (HCV-14). Turn the ECONOMIZER BACK PRESSURE REGULATOR (PCV-2) set screw counterclockwise to the end of its adjustment. Open TOP AND BOTTOM FILL VALVES (HCV-1 / HCV-2). Vent pressure by opening FILL DRAIN VALVE (HCV-7). Close TOP AND BOTTOM FILL VALVES (HCV-1 / HCV-2) and FILL DRAIN VALVE (HCV-7). Carefully loosen the PRESSURE RELIEF VALVE (TSV-4) to release any pressure in the line. When repairs are complete, purge lines and retighten the PRESSURE RELIEF VALVE (TSV-4) and pressure test all joints that were disassembled.

Order replacement parts from the valve manufacturer. Be sure to give all information on the valve nameplate, including the factory Part Number, as well as Taylor-Wharton part number listed in the "Replacement Parts" provided in this manual to ensure receiving the correct parts for these special valves.

## ***RESETTING CONTROL VALVES***

Use the following procedures to change control valve settings or to readjust the valves after completing repairs of the valves.

The PRESSURE BUILDING REGULATOR (PCV-1) should be set so that tank pressure is held about 5 psig (0.34 bar / 34 kPa) above the desired delivery pressure. The ECONOMIZER BACK PRESSURE REGULATOR (PCV-2) should be set at least 10 psig (0.7 bar / 70 kPa) above the setting of the PRESSURE BUILDING REGULATOR (PCV-1). If both controls are to be reset, set the PRESSURE BUILDING REGULATOR (PCV-1) before setting the ECONOMIZER BACK PRESSURE REGULATOR (PCV-2).

NOTE: The tank must contain liquid for setting control valves. The ECONOMIZER REGULATOR (PCV-2) must be adjusted while product is being withdrawn through the product withdrawal line.

***SETTING PRESSURE BUILDING REGULATOR (PCV-1):***

1. If tank pressure is below desired setting: Loosen pressure screw locknut on REGULATOR (PCV-1). With PRESSURE BUILDING ISOLATION VALVE (HCV-3) and PRESSURE BUILDING ISOLATION VALVE (HCV-11) open, gradually open REGULATOR (PCV-1) by turning pressure screw in (clockwise) to build tank pressure to 5 psig (0.34 bar / 34 kPa) above the desired delivery pressure. Note that the pressure screw must be adjusted in small increments, allowing sufficient time for tank pressure to stabilize each time the screw is turned. When desired set point is reached, tighten pressure screw locknut.
2. If tank pressure is above desired setting: Loosen pressure screw locknut and turn pressure screw out (counterclockwise) to end of adjustment range. Open TANK BLOWDOWN VALVE (HCV-12) and vent until tank pressure is 5 psig (0.34 bar / 34 kPa) above desired delivery pressure. With PRESSURE BUILDING ISOLATION VALVE (HCV-3) and PRESSURE BUILDING ISOLATION VALVE (HCV-11) open, slowly turn pressure screw in (clockwise) until REGULATOR (PCV-1) just opens as indicated by cooling of downstream pipe (at REGULATOR outlet). Tighten pressure screw locknut.

***SETTING ECONOMIZER BACK PRESSURE REGULATOR (PCV-2):***

1. Loosen ECONOMIZER BACK PRESSURE REGULATOR (PCV-2) pressure screw locknut and turn pressure screw in (clockwise) to end of adjustment range. Check that the PRESSURE BUILDING ISOLATION VALVES (HCV-3) and (HCV-11) are open.
2.
  - a. If tank pressure is below desired set point: Build pressure by opening both fill valves. Note that the fill connection must be securely blanked off. As tank pressure increases to desired set point-- at least 10 psig (0.7 bar / 70 kPa) above setting of PRESSURE BUILDING REGULATOR (PCV-1) close BOTTOM FILL VALVE (HCV-1). When liquid in line vaporizes, close the TOP FILL VALVE (HCV-2). Relieve any residual pressure by momentarily opening HOSE DRAIN VALVE (HCV-7).
  - b. If tank pressure is above desired set point: Open TANK BLOWDOWN VALVE (HCV-12) and vent until tank pressure is at desired set point -- at least 10 psi (0.7 bar / 70 kPa) above setting of PRESSURE BUILDING REGULATOR (PCV-1).

3. With tank pressure at desired ECONOMIZER BACKPRESSURE REGULATOR (PCV-2) set point, slowly turn pressure screw out (counterclockwise) until valve just opens as indicated by cooling of pipe between the ECONOMIZER BACKPRESSURE REGULATOR (PCV-2) and the ECONOMIZER ISOLATION VALVE (HCV-14).

### ***INNER VESSEL AND PIPING SAFETY DEVICES***

These tanks are equipped with a dual safety device manifold that permits servicing of one set of safety devices while the other set is in service.

If a pressure vessel RUPTURE DISC (PSE-1A,PSE-1B) ruptures, determine and correct the cause of the rupture before replacing the device. This device should be replaced annually as a preventive maintenance procedure. The bursting disc on this tank is a sealed assembly that must be replaced as a unit.

Main SAFETY VALVES (PSV-1A,PSV-1B) that leak or fail to operate at the set pressure should be replaced immediately. Repair and recalibration of these valves should only be done by experienced personnel with proper equipment. Return the valves to the manufacturer or to an ASME approved repair station for overhaul or recalibration.

Replace RELIEF VALVE (TSV-2, -3, -4) when leakage or improper functioning occurs. Do not attempt to repair or reseal these components since they are of the throw-away type.

### ***PRESSURE AND LIQUID LEVEL GAUGES***

The major cause of malfunctioning tank TANK PRESSURE GAUGE (PI-1), or LIQUID LEVEL GAUGE (LL-1) is an open EQUALIZATION VALVE (HCV-9) or leakage in the gauge lines. Refer to the Trouble-Remedy Guide in this manual for maintenance procedure. If the problem is not readily corrected, replace the gauge with a spare. Return the defective gauge to the manufacturer for repair. Include a description of the difficulty encountered.

## CASING VACUUM MAINTENANCE

### *CHECKING VACUUM*

Some vacuum deterioration may occur over an extended period of time due to out gassing of materials within the vacuum space or from leakage. A history of vacuum readings taken over a period of time can be valuable when evaluating tank performance and scheduling maintenance work.

To detect vacuum deterioration, periodic measurement of the tank vacuum is recommended. A thermocouple-type VACUUM GAUGE TUBE (VR-1), located on the lower head of the tank, is provided for this purpose

To check tank vacuum perform the following steps:

1. Remove the protective plastic cap from the gauge tube connector.
2. Connect a Hastings-Raydist Model No. TV-4A or VT-6 Vacuum Gauge to the VACUUM PROBE (VR-1).
3. Open the VACUUM PROBE ISOLATION VALVE (HCV-5) and wait at least 30 minutes before taking the vacuum reading.
4. After the vacuum reading is recorded, close the VACUUM PROBE ISOLATION VALVE (HCV-5), disconnect the Vacuum Gauge, and replace the protective cover on the VACUUM PROBE (VR-1) connector.

The vacuum reading obtained on a cold tank is initially less than 50 microns (0.05 mm Hg) absolute; however, gradual deterioration over an extended period of time is normal. A complete log of vacuum readings, along with dates when they were taken, can be very helpful in evaluating vacuum performance and scheduling maintenance work.

NOTE: If the tank is empty and warm, vacuum space pressure will tend to be high because of the release of gases from adsorbent package inside the vacuum space.

Because re-evacuation is time consuming and usually requires taking the tank out of service, it is not normally attempted until tank performance becomes unacceptable. Even a relatively high degree of deterioration can be tolerated in a tank from which high rates of withdrawal are being made. However, if vacuum deterioration seriously affects tank operation by producing excessive pressure buildup and high loss rates, contact the factory for information about how to determine and correct the cause of the trouble.

## ***VACUUM PROBE (VR-1) REPLACEMENT***

If the VACUUM PROBE TUBE (VR-1) is damaged or is suspected of giving inaccurate readings, replace it as follows:

1. Make certain that the VACUUM PROBE ISOLATION VALVE (HCV-5) is closed.
2. Unscrew the VACUUM PROBE (VR-1) from the VALVE (HCV-5). Using two wrenches.
3. Clean the threads and opening of the VALVE (HCV-5).

NOTE: Do not use Teflon tape as a sealant on vacuum system fittings.

4. Thread the new VACUUM PROBE (VR-1) into the VALVE (V-5) by engaging one thread. Apply a suitable high vacuum sealant to remaining exposed threads. Tighten the PROBE (VR-1) into VALVE (V-5), using two wrenches. Do not over tighten.
5. Install a new vinyl cover over the VACUUM PROBE (VR-1) connector.

NOTE: If corrosion of the PROBE (VR-1) is a problem at a particular location, spray the tube housing with "Krylon Crystal Clear Coating 1301" or equivalent acrylic spray. Do not spray the contact pins of the electrical connector; this could cause erroneous vacuum readings.

6. Open the VACUUM PROBE ISOLATION VALVE (HCV-5) and check vacuum following the above described procedure. The waiting period to obtain a stable reading with a new gauge tube may exceed the specified 30 minutes. This is due to out gassing of the new gauge tube and the thread sealant.

## ***ANALYZING VACUUM DETERIORATION***

If you decide to re-evacuate because of normal aging and deterioration, contact the factory for re-evacuation procedures. If vacuum deterioration occurs over a relatively short period and pressure is greater than 1,000 microns (1 mm Hg) absolute, suspect that a leak has developed in the external casing of the tank. If deterioration is rapid and causes the CASING RELIEF DEVICE (R-2) to function, suspect leakage from the liquid container or internal piping.

NOTE: An abnormally high vacuum reading without other evidence of vacuum loss (excessive pressure, rapid venting, etc.) maybe caused by a fault in the gauging equipment or by improper operation of the equipment. Be sure that the Vacuum Gauge and the VACUUM PROBE (VR-1) are in good condition and follow operating instructions carefully. Always be sure that the VACUUM PROBE ISOLATION VALVE (HCV-5) has been open for at least 30 minutes before taking a reading.

Try to determine the source of leakage in cases where the VACUUM JACKET LIFTPLATE (PSE-3) has not functioned, visually inspect the following areas in the order in which they are listed:

- a. VACUUM PROBE (VR-1),
- b. VACUUM PROBE ISOLATION VALVE (HCV-5),
- c. VACUUM PUMPOUT VALVE (HCV-6),
- d. Sealed insulation ports (on top of the tank),
- e. VACUUM JACKET LIFTPLATE (PSE-3),
- f. All liquid and gas phase lines exit points through vacuum jacket,
- g. Any area of the vacuum jacket that might have been exposed to cryogenic liquid spray or temperatures.

Look for signs of damage, corrosion, or damaged valves, and other abnormal conditions. Contact the factory for repair and re-evacuation procedures.

## **PAINTING**

If repainting of the vessel is required, be sure to use materials that are compatible with the factory-applied finish. The vessel was originally painted with the following materials:

Primer: Gavlon 8198 Zinc Rich Epoxy Polyamide/adduct  
5-6 dry mils thick

Finish Coat: Gavlon HS350 Modified Acrylic Urethane, Gloss White  
2-3 dry mils thick

### ***SAFETY PRECAUTIONS PERTAINING TO PAINTING OPERATIONS***

All paint components contain volatile solvents, mainly petroleum distillates, alcohols, xylene. Normal precautions for flammable materials should be observed including exclusion of heat, sparks, and open flame. Containers should be grounded before painting.

All the ingredients present physiological hazards both from inhalation and absorption through the skin. Breathing of the vapor and spray mist must be avoided. Protective clothing including rubber gloves must be worn. Allergy-prone individuals may be sensitized and should not be exposed to isocyanates.

Good industrial hygiene practice must be observed including thorough washing before eating or smoking.

## TROUBLE-REMEDY GUIDE

TROUBLE	POSSIBLE CAUSES	REMEDY
1. Tank Pressure too low.	<ul style="list-style-type: none"> <li>a. Safety Valve (PSV-1A/1B) leaking or frozen open.</li> <li>b. Rupture Disc (PSE-1A/1B) rupture.</li> <li>c. Piping leaks to atmosphere.</li> <li>d. Low liquid level.</li> <li>e. Excessive product withdrawal.</li> <li>f. Improper filling procedure.</li> </ul>	<ul style="list-style-type: none"> <li>a. Thaw out valve or replace if necessary. Refer to Step 5, this section.</li> <li>b. Replace Rupture Disc (PSE-1A/1B). Refer to Step 6, this section.</li> <li>c. Test and repair tank</li> <li>d. Refill tank.</li> <li>e. Install higher capacity Pressure Building Coil.</li> <li>f. Refer to filling instruction in Operation Section.</li> </ul>
2. Excessive tank pressure.	<ul style="list-style-type: none"> <li>a. Extensive shutdown time.</li> <li>b. Low withdrawal rate.</li> <li>c. Malfunction of Pressure Building Regulator (PCV-1).</li> <li>d. Malfunction of tank Pressure Gauge, Inner Vessel.</li> <li>e. Lack of refrigeration caused by low liquid level.</li> </ul>	<ul style="list-style-type: none"> <li>a. No Remedy.</li> <li>b. No Remedy.</li> <li>c. Refer to Step 3, this section.</li> <li>d. Replace Pressure Gauge, Inner Vessel.</li> <li>e. Refill tank.</li> </ul>
3. Malfunction of Back Pressure Valve.	<ul style="list-style-type: none"> <li>a. Improper valve set point.</li> <li>b. Dirt on valve seat or valve component.</li> </ul>	<ul style="list-style-type: none"> <li>a. Check valve set point reset if required, follow in Resetting Control Valves section.</li> <li>b. Disassemble, inspect, clean, and reassemble per instructions of manufacturer.</li> </ul>
4. Erratic or erroneous Liquid Level Gauge readings.	<ul style="list-style-type: none"> <li>a. Leaking gauge lines.</li> <li>b. By-pass valve open.</li> <li>c. Liquid Level Gauge needle stuck.</li> <li>d. Liquid Level Gauge needle not zero adjusted.</li> <li>e. Gauge line reversed.</li> <li>f. Liquid Level Gauge damaged or faulty.</li> <li>g. Plugged gauge lines.</li> </ul>	<ul style="list-style-type: none"> <li>a. Test and repair leaks.</li> <li>b. Close by-pass valve.</li> <li>c. Tap Liquid Level Gauge slightly, Inspect needle and bend as required.</li> <li>d. Adjust as required.</li> <li>e. Connect properly.</li> <li>f. Replace Liquid Level Gauge.</li> <li>g. Disconnect lines at Liquid Level Gauge and test for flow.</li> </ul>
5. Leaking safety valve.	<ul style="list-style-type: none"> <li>a. Dirt or ice under valve or disc.</li> <li>b. Improper valve set point.</li> <li>c. Damaged valve seat or disc.</li> </ul>	<ul style="list-style-type: none"> <li>a. Thaw out valve. Replace if necessary.</li> <li>b. Replace valve.</li> <li>c. Replace valve.</li> </ul>
6. Ruptured Pressure Vessel Rupture	<ul style="list-style-type: none"> <li>a. Excessive tank pressure.</li> </ul>	<ul style="list-style-type: none"> <li>a. Refer to Step 2, this section. Replace</li> </ul>

Disc.	<ul style="list-style-type: none"> <li>b. Defective Rupture Disc (PSE-1A/1B).</li> <li>c. Atmosphere corrosion and/or disc fatigue.</li> <li>d. Interior disc corrosion.</li> <li>e. Improper Rupture Disc (PSE-1A/1B).</li> </ul>	<p>Rupture Disc (PSE-1A/1B).</p> <ul style="list-style-type: none"> <li>b. Replace Rupture Disc (PSE-1A/1B).</li> <li>c. Replace Rupture Disc (PSE-1A/1B).</li> <li>d. Blow out safety device line. Replace Rupture Disc (PSE-1A/1B).</li> <li>e. Install correct Rupture Disc (PSE-1A/1B).</li> </ul>
7. Tank vacuum leak.	<ul style="list-style-type: none"> <li>a. Leak in Vacuum Jacket Lift Plate (PSE-3).</li> <li>b. Vacuum Pump out Valve (HCV-6) leak.</li> <li>c. Vacuum Probe (VR-1) or Vacuum Probe Isolation Valve (HCV-5) leak.</li> </ul>	<ul style="list-style-type: none"> <li>a. Refer to Analyzing Vacuum Deterioration section. Replace Vacuum Jacket Lift Plate (PSE-3).</li> <li>b. Replace Vacuum Pump out Valve (HCV-6) diaphragm. Re-evacuate insulation space. Contact the factory for re-evacuation procedures.</li> <li>c. Replace faulty component. Re-evacuate insulation space. Contact the factory for re-evacuation procedures.</li> </ul>

## RECOMMENDED TOOLS, EQUIPMENT, AND MATERIALS

Components in the "Reference" column are provided to indicate where various tools, equipment, and material are used. For locations of various suppliers listed, refer to the Address List section.

REFERENCE	DESCRIPTION	PART NUMBER	SOURCE
All Hand Valves	Preformed Packing	-	Valve Manufacture
Liquid Level Gauge	Pointer Puller	-	ITT Barton
Vacuum Gauge Tube	Krylon Crystal Clear Coating	1301	Borden
	Vacuum Gauge	TV-4A, VT-6	Teledyne Hastings-Raydist
	Liquid High Vacuum Sealant 4oz.	4036	Airserco Mfg. Co.
	Epoxy	A-12	Armstrong Prod.
Vacuum Jacket Relief Device	Celevacene Grease	-	Consolidated Vacuum Corp.
	Chlorothene VG	-	Dow Chemical Co.

## REPLACEMENT PARTS

Order replacement parts from Taylor-Wharton, Theodore, Alabama or the prime manufacturer. All replacement parts must be cleaned for oxygen service before installation on the tank. If ordering from the prime manufacturer, provide the Taylor-Wharton part number and all identifying information with part being serviced. Refer to each tank's Flow Diagram.

**REPLACEMENT PARTS LIST - OPTION 1**

ITEM	PART NUMBER	DESCRIPTION	1500	3000	6000	9000	11000	13000	15000
CV-1	8544-1756	Valve, Check, 1.62" ODT	x	x	x	x	x	x	x
CV-2	8544-1368	Valve, Check, 0.50" FPT	x	x	x	x	x	x	x
HCV-1, HCV-2	615207	Valve, Angle, 1.62" ODT	x	x	x	x	x	x	x
HCV-3, HCV-11	2100145	Valve, Gate, 0.625" ODT	x	x	x	x	x	x	x
HCV-4	8545-4025	Valve, Globe, 0.38" FNPT	x	x	x	x	x	x	x
HCV-5	612921	Valve, Vacuum, 0.12" MPT	x	x	x	x	x	x	x
HCV-6	8545-0151	Valve, Vacuum, 1.5" MPT	x	x	x	x	x	x	x
HCV-7	8545-0361	Valve, Globe, 0.25" FPT	x	x	x	x	x	x	x
HCV-8, HCV-9 HCV-10	8544-3725	Valve, Globe, 0.25" MPT	x	x	x	x	x	x	x
HCV-12	8544-4361	Valve, Globe, 1.0" FPT	x	x	x	x	x	x	x
HCV-13	85442355	Valve, Gate, 1.0" FPT	x	x	x	-	-	-	-
HCV-13	2100174	Valve, Gate, 1.5" FPT	-	-	-	x	x	x	x
HCV-14	8544-2274	Valve, Globe, 0.62" ODT	x	x	x	x	x	x	x
HCV-15	2098588	Valve, Diverter, 1.0" Globe	x	x	x	x	x	x	x
HCV-17	85442355	Valve, Gate, 1.0" FPT	x	x	x				
HCV-17	2100174	Valve, Gate, 1.5" FPT	-	-	-	x	x	x	x
LI-1	5740-8860	D.P. Gauge, 0-200" Water	x	x	-	-	-	-	-
LI-1	5740-8865	D.P. Gauge, 0-400" Water	-	-	x	x	x	-	-
LI-1	5740-8870	D.P. Gauge, 0-500" Water	-	-	-	-	-	x	-
LI-1	5740-8872	D.P. Gauge, 0-600" Water	-	-	-	-	-	-	x
PCV-1	8536-8059	Pressure Regulator , 0.375" FPT, set at 150 psig	x	x	x	x	x	x	x
PCV-2	902190	Back Pressure Regulator, 0.50" FPT, set at 185 psig	x	x	x	x	x	x	x
PSE-3	2200763	O-Ring Relief, 6"	x	x	x	x	x	x	-
PSE-3	2050856	O-Ring Relief, 10"	-	-	-	-	-	-	x
PSE-1A, PSE-1B	2207679	Safety Head, 0.75", 330-357 psi	x	x	x	x	x	x	x
PSV-1A, PSV-1B	8545-0325	Safety Valve, 0.75" MPT x 1.0" FPT, 250 psig	x	x	x	x	x	x	x
PI-1	5714-3490	Pressure Gauge, 0.25 MPT, 0-400 psi	x	x	x	x	x	x	x
S-1	615200	Strainer,	x	x	x	x	x	x	x
TSV-2, TSV-3, TSV-4	587695	Valve, Relief, 0.25", 350 psig set pressure	x	x	x	x	x	x	x
VR-1	5740-8470	Vacuum Gauge Tube, 0-1000 Micron Range	x	x	x	x	x	x	x
	2214289	Operational Flow sheet	x	x	x	x	x	x	x
	936178	Contents Chart	x	-	-	-	-	-	
	936179	Contents Chart	-	x	-	-	-	-	
	936180	Contents Chart	-	-	x	-	-	-	
	2214363	Contents Chart	-	-	-	x	-	-	
	936182	Contents Chart	-	-	-	-	x	-	
	2064970	Contents Chart	-	-	-	-	-	x	
	2210714	Contents Chart	-	-	-	-	-	-	x

**REPLACEMENT PARTS LIST - OPTION 2**

ITEM	PART NUMBER	DESCRIPTION	1500	3000	6000	9000	11000	13000	15000
CV-1	8544-1750	Valve, Check, 1.50" FPT	x	x	x	x	x	x	x
CV-2	8544-1368	Valve, Check, 0.50" FPT	x	x	x	x	x	x	x
HCV-1, HCV-2	615207	Valve, Angle, 1.62" ODT	x	x	x	x	x	x	x
HCV-3, HCV-11	2100145	Valve, Gate, 0.625" ODT	x	x	x	x	x	x	x
HCV-4	8545-4025	Valve, Globe, 0.38" FNPT	x	x	x	x	x	x	x
HCV-5	612921	Valve, Vacuum, 0.12" MPT	x	x	x	x	x	x	x
HCV-6	8545-0151	Valve, Vacuum, 1.5" MPT	x	x	x	x	x	x	x
HCV-7	2198262	Valve, Globe, 0.375" FPT	x	x	x	x	x	x	x
HCV-8, HCV-9 HCV-10	8544-3725	Valve, Globe, 0.25" MPT	x	x	x	x	x	x	x
HCV-12	8544-4365	Valve, Globe, 1.0" FPT	x	x	x	x	x	x	x
HCV-13	8544-2365	Valve, Globe, 1.0" FPT	x						
HCV-13	8544-2684	Valve, Gate, 1.5" FPT		x	x	x	x	x	x
HCV-14	8544-2274	Valve, Globe, 0.62" ODT	x	x	x	x	x	x	x
HCV-16A HCV-16B	8544-3725	Valve, Globe, 0.25" MPT	x	x	x	x	x	x	x
HCV-15	2098588	Valve, Diverter, 1.0" Globe	x	x	x	x	x	x	x
HCV-17	85442355	Valve, Gate, 1.0" FPT	-	-	-	-	-	-	-
HCV-17	8544-2684	Valve, Gate, 1.5" FPT	-	-	x	x	x	x	x
LI-1	5740-8861	D.P. Gauge/Switch, 0-200" Water	x	x	-	-	-	-	-
LI-1	5740-8866	D.P. Gauge/Switch, 0-400" Water	-	-	x	x	x	-	-
LI-1	5740-8871	D.P. Gauge/Switch, 0-500" Water	-	-	-	-	-	x	-
LI-1	5740-8873	D.P. Gauge/Switch, 0-600" Water	-	-	-	-	-	-	x
PCV-1	8536-2675	Pressure Regulator , 0.50" FPT	x	x	x	x	x	x	x
PCV-2	902190	Back Pressure Regulator, 0.50" FPT, set at 185 psig	x	x	x	x	x	x	x
PSE-3	2200763	O-Ring Relief, 6"	x	x	x	x	x	x	
PSE-3	2050856	O-Ring Relief, 10"							x
PSE-1A, PSE-1B	2209522	Safety Head, 0.75", 330-390 psi @ 72 F, 240-275 psi @ 800 F	x	x	x	x	x	x	x
PSV-1A, PSV-1B	8545-0320	Safety Valve, 0.50" MPT x 0.75" FPT, 250 psig	x	x	x	x	x	x	x
PI-1	5714-3490	Pressure Gauge, 0.25 MPT, 0-400 psi	x	x	x	x	x	x	x
S-1	615200	Strainer,	x	x	x	x	x	x	x
TSV-2, TSV-3, TSV-4	587695	Valve, Relief, 0.25", 350 psig set pressure	x	x	x	x	x	x	x
VR-1	5740-8470	Vacuum Gauge Tube, 0-1000 Micron Range	x	x	x	x	x	x	x
	2214289	Operational Flow sheet	x	x	x	x	x	x	x
	936178	Contents Chart	x	-	-	-	-	-	-
	936179	Contents Chart	-	x	-	-	-	-	-
	936180	Contents Chart	-	-	x	-	-	-	-
	2214363	Contents Chart	-	-	-	x	-	-	-
	936182	Contents Chart	-	-	-	-	x	-	-
	2064970	Contents Chart	-	-	-	-	-	x	-

	2210714	Contents Chart	-	-	-	-	-	-	X
--	---------	----------------	---	---	---	---	---	---	---

### REPLACEMENT PARTS LIST - OPTION 3

ITEM	PART NUMBER	DESCRIPTION	1500	3000	6000	9000	11000	13000	15000
CV-1	8544-1750	Valve, Check, 1.5" FPT	x	x	x	x	x	x	x
FB-1	2202366	Linde Fill Flange	x	x	x	x	x	x	x
HCV-1, HCV-2	615207	Valve, Angle, 1.62" ODT	x	x	x	x	x	x	x
HCV-3, HCV-11	8544-4560	Valve, Globe, 1.625" ODT	x	x	x	x	x	x	x
HCV-4	8545-4025	Valve, Globe, 0.38" FNPT	x	x	x	x	x	x	x
HCV-5	612921	Valve, Vacuum, 0.12" MPT	x	x	x	x	x	x	x
HCV-6	8545-0151	Valve, Vacuum, 1.5" MPT	x	x	x	x	x	x	x
HCV-7	8545-4025	Valve, Globe, 0.375" FPT	x	x	x	x	x	x	x
HCV-8, HCV-10	8544-3725	Valve, Globe, 0.25" MPT	x	x	x	x	x	x	x
HCV-12	8544-4345	Valve, Globe, 1.0" FPT	x	x	x	x	x	x	x
HCV-13	8544-2345	Valve, Globe, 1.0" FPT	x	x	x	x	x	x	x
HCV-14	8544-4044	Valve, Globe, 0.62" ODT	x	x	x	x	x	x	x
HCV-15	8544-9407	Valve, Diverter, Customer Supplied	x	x	x	x	x	x	x
HCV-16A HCV-16B	8544-3725	Valve, Globe, 0.25" MPT	x	x	x	x	x	x	x
HCV-17	8544-2345	Valve, Globe, 1.0" FPT	x	-	-	-	-	-	-
HCV-17	8544-4569	Valve, Globe, 1.5" FPT	-	x	x	x	x	x	x
LI-1	5740-8860	D.P. Gauge, 0-200" Water	x	x	-	-	-	-	-
LI-1	5740-8865	D.P. Gauge, 0-400" Water	-	-	x	x	x	-	-
LI-1	5740-8870	D.P. Gauge, 0-500" Water	-	-	-	-	-	x	-
LI-1	5740-8872	D.P. Gauge, 0-600" Water	-	-	-	-	-	-	x
PCV-1	8536-8132	Pressure Regulator , 0.625" ODT, set at 150 psig	x	x	x	x	x	x	x
PCV-2	8536-2609	Back Pressure Regulator, 0.625" ODT, set at 165 psig	x	x	x	x	x	x	x
PSE-3	2200763	O-Ring Relief, 6"	x	x	x	x	x	x	
PSE-3	2050856	O-Ring Relief, 10"							x
PSE-1A, PSE-1B	8508-5515	Safety Head, 1.0", 326-375 psi @ 72 F, 239-275 psi @ 800 F	x	x	x	x	x	x	x
PSV-1A, PSV-1B	8545-0321	Safety Valve, 0.50" MPT x 0.5" FPT, 250 psig	x	x	x	x	x	x	x
PI-1	5714-3490	Pressure Gauge, 0.25 MPT, 0-400 psi	x	x	x	x	x	x	x
TSV-2, TSV-3, TSV-4	8545-0291	Valve, Relief, 0.25", 400 psig set pressure	x	x	x	x	x	x	x
VR-1	5740-8470	Vacuum Gauge Tube, 0-1000 Micron Range	x	x	x	x	x	x	x
	2214289	Operational Flow sheet	x	x	x	x	x	x	x
	936178	Contents Chart	x	-	-	-	-	-	-
	936179	Contents Chart	-	x	-	-	-	-	-
	936180	Contents Chart	-	-	x	-	-	-	-
	2214363	Contents Chart	-	-	-	x	-	-	-

	936182	Contents Chart	-	-	-	-	X	-	-
	2064970	Contents Chart	-	-	-	-	-	X	-
	2210714	Contents Chart	-	-	-	-	-	-	X

### REPLACEMENT PARTS LIST - OPTION 4

ITEM	PART NUMBER	DESCRIPTION	1500	3000	6000	9000	11000	13000	15000
CV-1	8544-1756	Valve, Check, 1.62" ODT	x	x	x	x	x	x	x
CV-2	8544-1368	Valve, Check, 0.50" FPT	x	x	x	x	x	x	x
HCV-1, HCV-2	615207	Valve, Angle, 1.62" ODT	x	x	x	x	x	x	x
HCV-3, HCV-11	8544-4044	Valve, Globe, 0.625" ODT	x	x	x	x	x	x	x
HCV-4	8545-4025	Valve, Globe, 0.38" FNPT	x	x	x	x	x	x	x
HCV-5	612921	Valve, Vacuum, 0.12" MPT	x	x	x	x	x	x	x
HCV-6	8545-0151	Valve, Vacuum, 1.5" MPT	x	x	x	x	x	x	x
HCV-7	8545-0361	Valve, Globe, 0.25" FPT	x	x	x	x	x	x	x
HCV-8, HCV-9 HCV-10	8544-3725	Valve, Globe, 0.25" MPT	x	x	x	x	x	x	x
HCV-12	8544-4345	Valve, Globe, 1.0" FPT	x	x	x	x	x	x	x
HCV-13	8544-4345	Valve, Globe, 1.0" FPT	x	x	x				
HCV-13	85444569	Valve, Globe, 1.5" FPT				x	x	x	x
HCV-14	8544-4044	Valve, Globe, 0.625" ODT	x	x	x	x	x	x	x
HCV-15	2098588	Valve, Diverter, 1.0" Globe	x	x	x	x	x	x	x
HCV-16A HCV-16B	8544-3725	Valve, Globe, 0.25" MPT	x	x	x	x	x	x	x
HCV-17	8544-4345	Valve, Globe, 1.0" FPT	x	-	-	-	-	-	-
HCV-17	85444569	Valve, Globe, 1.5" FPT	-	x	x	x	x	x	x
LI-1	5740-8860	D.P. Gauge, 0-200" Water	x	x	-	-	-	-	-
LI-1	5740-8865	D.P. Gauge, 0-400" Water	-	-	x	x	x	-	-
LI-1	5740-8870	D.P. Gauge, 0-500" Water	-	-	-	-	-	x	-
LI-1	5740-8872	D.P. Gauge, 0-600" Water	-	-	-	-	-	-	x
PCV-1	8536-8130	Pressure Regulator , 0.375" FPT, set at 150 psig	x	x	x	x	x	x	x
PCV-2	902190	Back Pressure Regulator, 0.50" FPT, set at 185 psig	x	x	x	x	x	x	x
PSE-3	2200763	O-Ring Relief, 6"	x	x	x	x	x	x	-
PSE-3	2050856	O-Ring Relief, 10"	-	-	-	-	-	-	x
PSE-1A, PSE-1B	2207679	Safety Head, 0.75", 330-357 psi	x	x	x	x	x	x	x
PSV-1A, PSV-1B	8545-0325	Safety Valve, 0.75" MPT x 1.0" FPT, 250 psig	x	x	x	x	x	x	x
PI-1	5714-3490	Pressure Gauge, 0.25 MPT, 0- 400 psi	x	x	x	x	x	x	x
S-1	615200	Strainer,	x	x	x	x	x	x	x
TSV-2, TSV-3, TSV-4	587695	Valve, Relief, 0.25", 350 psig set pressure	x	x	x	x	x	x	x
VR-1	5740-8470	Vacuum Gauge Tube, 0-1000 Micron Range	x	x	x	x	x	x	x
	2214289	Operational Flow sheet	x	x	x	x	x	x	x
	936178	Contents Chart	x	-	-	-	-	-	-
	936179	Contents Chart	-	x	-	-	-	-	-
	936180	Contents Chart	-	-	x	-	-	-	-
	2214363	Contents Chart	-	-	-	x	-	-	-
	936182	Contents Chart	-	-	-	-	x	-	-

	2064970	Contents Chart	-	-	-	-	-	X	-
	2210714	Contents Chart	-	-	-	-	-	-	X

## TANK PART AND GENERAL ARRANGEMENT DRAWING NUMBERS

### OPTION 1

TANK SIZE	MAWP	PART NUMBER	GENERAL ARRANGEMENT DRAWING
1500	250	2214009	B-2214299
3000	250	2214010	B-2214299
6000	250	2214011	B-2214299
9000	250	2214240	B-2214299
11000	250	2214012	B-2214299
13000	250	2214013	B-2214299
15000	250	2214014	B-2214299

### OPTION 2

TANK SIZE	MAWP	PART NUMBER	GENERAL ARRANGEMENT DRAWING
1500	250	2214015	B-2214300
3000	250	2201016	B-2214300
6000	250	2214017	B-2214300
9000	250	2214241	B-2214300
11000	250	2214018	B-2214300
13000	250	2214019	B-2214300
15000	250	2214020	B-2214300

### OPTION 3

TANK SIZE	MAWP	PART NUMBER	GENERAL ARRANGEMENT DRAWING
1500	250	2214021	B-2214301
3000	250	2201022	B-2214301
6000	250	2214023	B-2214301
9000	250	2214242	B-2214301
11000	250	2214024	B-2214301
13000	250	2214025	B-2214301
15000	250	2214026	B-2214301

### OPTION 4

TANK SIZE	MAWP	PART NUMBER	GENERAL ARRANGEMENT DRAWING
1500	250	2214258	B-2214302
3000	250	2201259	B-2214302
6000	250	2214260	B-2214302
9000	250	2214261	B-2214302
11000	250	2214262	B-2214302
13000	250	2214263	B-2214302
15000	250	2214264	B-2214302



4275 Hamilton Blvd  
Theodore Alabama 36582 U.S.A.  
Telephone (344) 443-8680  
Fax (344) 443-2250  
In U.S. and Canada:  
(800) TW TANKS (898-2657)  
[cryotanks@taylorwharton.com](mailto:cryotanks@taylorwharton.com)